

# Hyspan VENTURI

## FLOW MEASUREMENT SYSTEM / SERIES V5 STEEL

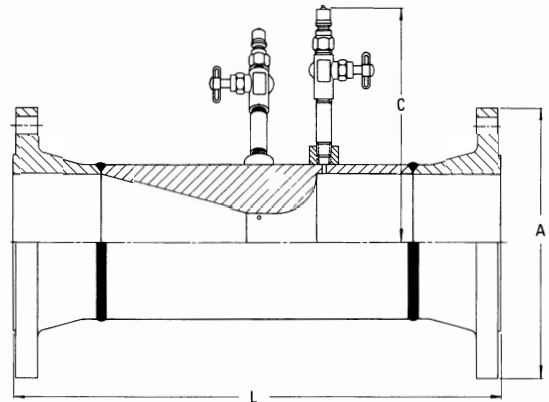
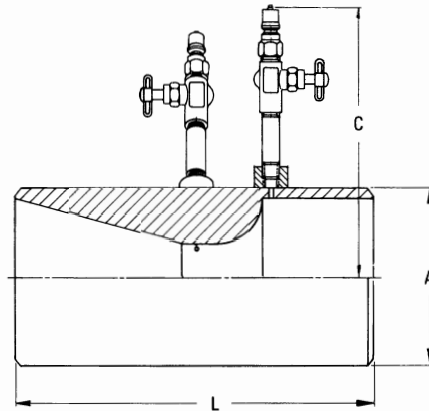
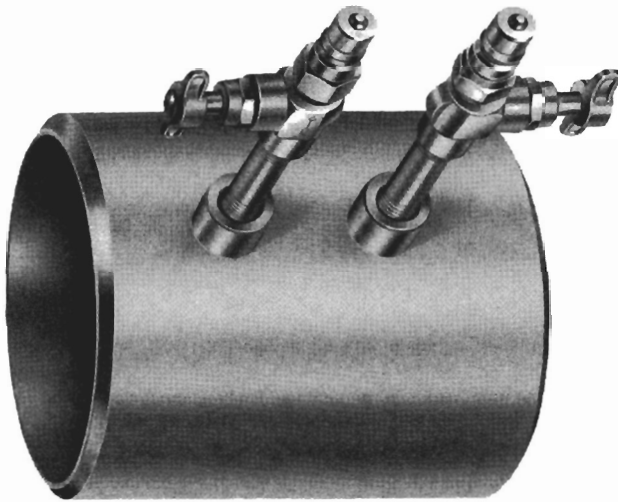

Series V5 Steel Venturis are available in sizes from 2 1/2" thru 10", with flanged or weld ends. Shipped with identification tags and fitting kit (brass nipples, brass valves and color-coded quick connect couplings) attached.

All **HYSpan** Venturis are shipped with a permanently attached tag which shows the correct capacity curve for converting meter readings to gpm.

Other materials, schedule weld ends, flanges, etc., are available on request.

All dimensions in inches.

Pipe Size	Beta Ratio	Size Code	End Code	COMPLETE PART NUMBER	A Diam.	C	L	End Connection	Weight each (lbs.)	Rating PSI at +250°F.*
2 1/2	480	40	41	BR29480-40-41	7.00	6.26	11.25	150# Flange	25.0	225**
	480	40	61	BR29480-40-61	3.10	6.26	5.50	Sch. 40 .203 Wall	5.5	500†
	607	40	41	BR29607-40-41	7.00	6.26	10.50	150# Flange	23.5	225**
	607	40	61	BR29607-40-61	3.10	6.26	4.75	Sch. 40 .203 Wall	5.0	500†
	750	40	41	BR29750-40-41	7.00	6.26	9.75	150# Flange	22.0	225**
	750	40	61	BR29750-40-61	3.10	6.26	4.00	Sch. 40 .203 Wall	4.0	500†
3	478	48	41	BR29478-48-41	7.50	6.56	11.75	150# Flange	34.0	225**
	478	48	61	BR29478-48-61	3.79	6.56	6.00	Sch. 40 .216 Wall	8.0	500†
	610	48	41	BR29610-48-41	7.50	6.56	11.00	150# Flange	32.0	225**
	610	48	61	BR29610-48-61	3.79	6.56	5.25	Sch. 40 .216 Wall	7.0	500†
	750	48	41	BR29750-48-41	7.50	6.56	10.25	150# Flange	30.0	225**
	750	48	61	BR29750-48-61	3.79	6.56	4.50	Sch. 40 .216 Wall	6.0	500†

# HOW TO ORDER

To order a **HYPAN** Venturi, state the complete part number, as shown in color below. The part number consists of the following elements: first, a basic assembly number which designates the type of venturi; second, the beta ratio; third, the size; and fourth, the end code. Below is a typical example.

End Codes

**41** = 150 lb. Flange    **61** = Weld End    **81** = Grooved End

Complete Part Number

**BR29465-64-41**

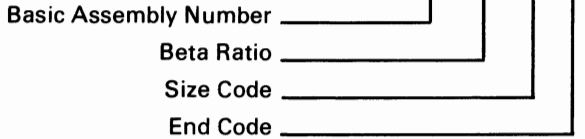

\* For pressure rating of fittings, see page 25.

\*\* When flanges are used, venturi body without fitting kit is rated at the flange pressure rating, i.e., ANSI 150 lb., ANSI 300 lb., or ANSI 600 lb. (2", 2½" and 3" only).

† Pressure rating of venturi body without fitting kit for 2", 2½", 3" and 4" is designed to meet ANSI 600 lb. ratings, i.e., 1440 psig up to +100°F., 1100 psig up to +600°F.

‡ Pressure rating of venturi body without fitting kit for 5", 6", 8", and 10" is designed to meet ANSI 300 lb. ratings, i.e., 720 psig up to +100°F., 550 psig up to +600°F.

All dimensions in inches.

Pipe Size	Beta Ratio	Size Code	End Code	COMPLETE PART NUMBER	A Diam.	C	L	End Connection	Weight each (lbs.)	Rating PSI at +250°F.*
<b>4</b>	465	64	41	BR29465-64-41	9.00	7.04	13.75	150# Flange	47.0	225**
	465	64	61	BR29465-64-61	4.89	7.04	7.50	Sch. 40 .237 Wall	17.0	500†
	620	64	41	BR29620-64-41	9.00	7.04	12.50	150# Flange	42.0	225**
	620	64	61	BR29620-64-61	4.89	7.04	6.25	Sch. 40 .237 Wall	14.0	500†
	745	64	41	BR29745-64-41	9.00	7.04	11.50	150# Flange	40.0	225**
	745	64	61	BR29745-64-61	4.89	7.04	5.25	Sch. 40 .237 Wall	12.0	500†
<b>5</b>	572	65	41	BR29572-65-41	10.00	7.61	14.75	150# Flange	58.0	225**
	572	65	61	BR29572-65-61	5.91	7.61	7.50	Sch. 40 .258 Wall	21.0	500†
	718	65	41	BR29718-65-41	10.00	7.61	12.75	150# Flange	51.0	225**
	718	65	61	BR29718-65-61	5.91	7.61	5.50	Sch. 40 .258 Wall	15.0	500†
<b>6</b>	628	66	41	BR29628-66-41	11.00	8.12	15.25	150# Flange	74.0	225**
	628	66	61	BR29628-66-61	6.92	8.12	8.00	Sch. 40 .280 Wall	29.0	500‡
	750	66	41	BR29750-66-41	11.00	8.12	13.25	150# Flange	64.0	225**
	750	66	61	BR29750-66-61	6.92	8.12	6.00	Sch. 40 .280 Wall	21.0	500‡
<b>8</b>	615	68	41	BR29615-68-41	13.50	9.12	18.25	150# Flange	123.0	225**
	615	68	61	BR29615-68-61	8.96	9.12	10.00	Sch. 40 .322 Wall	49.0	500‡
	743	68	41	BR29743-68-41	13.50	9.12	16.25	150# Flange	110.0	225**
	743	68	61	BR29743-68-61	8.96	9.12	8.00	Sch. 40 .322 Wall	39.0	500‡
<b>10</b>	605	70	41	BR29605-70-41	16.00	10.12	21.00	150# Flange	154	225**
	605	70	61	BR29605-70-61	10.75	10.12	13.00	Sch. 40 .365 Wall	62	500
	796	70	41	BR29796-70-41	16.00	10.12	17.00	150# Flange	138	225**
	796	70	61	BR29796-70-61	10.75	10.12	9.00	Sch. 40 .365 Wall	50	500