

Technical Notes

for

Metal Bellows Expansion Joints

and

Packed Expansion Joints



OUTLINE

1. Basic Principles
2. The Most Frequent Application
3. Axial Movement Applications
4. Pressure Balanced Expansion Joints (Axial)
5. Lateral Movement Applications-Universal Tied Expansion Joint
6. Pressure Balanced Expansion Joints (Lateral)
7. Hinged Expansion Joints
8. Gimbal Expansion Joints
9. Ductwork Expansion Joints
10. Single Ply vs Laminated Bellows
11. Low Corrugation vs High Corrugation
12. Bellows Stability
13. Externally Pressurized Guided Expansion Joints
14. Symbols
15. Applications Section
16. Information Needed for a Quotation
17. Packed Expansion Joint Section
18. In-Line Pressure Balanced Universal Expansion Joint

BASIC PRINCIPLES: Metal Bellows Expansion Joints

Thermal movement in pipelines and ducting is produced by the following:

1. The temperature of the system when installed (or not in operation) is different from the operating temperature.
2. The temperature cycles during the system's normal operation.
3. The system is exposed to variations in ambient temperature.

If these thermal movements (expansion with increasing temperature and contraction with decreasing temperature) are not compensated for in the system design, they may cause high stress, and possibly result in failure of the piping or connected equipment.

There are three basic methods of compensation for thermal movement in a piping system:

1. Design a flexible piping system which utilizes changes of direction to absorb movement.
2. Use pipe loops or bends to absorb the movement.
3. Use expansion devices such as metal bellows expansion joints, packed expansion joints, ball joints, and flexible metal hose.

Flexible piping systems and pipe loops are seldom feasible or economical where space is limited. Even if space limitations are not a factor, the cost of extra pipe, insulation and supports for a flexible piping system or loops often exceeds the cost of expansion joints to do the same job. Further, the extra heat loss and pressure drop resulting from the increased length for the pipe loops may increase operating costs.

Hyspan manufactures a complete range of metal bellows expansion joints. A bellows is a flexible seal. This convoluted part of the joint is designed to flex when thermal movement in the piping system occurs. Thus, by determining the thermal movement that will occur in the piping system, expansion joints may be specified, manufactured and installed in the system to accommodate these movements.

A bellows can be designed and fabricated to absorb axial, lateral and angular movements. Expansion applications can require one, two or three motions in a single expansion joint design.

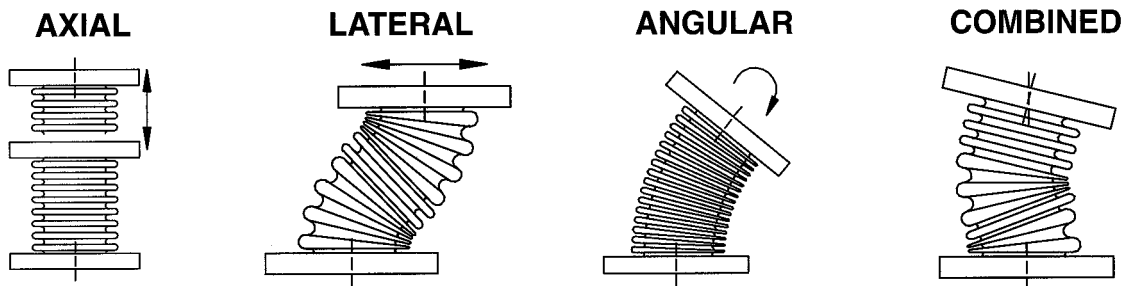

WARNING: Bellows cannot absorb torsional rotation (the twisting of one end with respect to the other end about its longitudinal axis).

We have just noted how placing a flexible metal bellows at selected locations in a piping system can accommodate its thermal movement. There are some side effects which occur when a pipe is cut in two and a bellows (flexible seal) inserted to take the movement of the pipe.

1. Pressure Thrust

By its very nature of being flexible (to absorb movement) a bellows will extend (straighten out) due to the line pressure. This pressure thrust must then be absorbed by some means or the line will tear itself apart. This force may be accommodated by anchoring the pipe or by using an expansion joint which incorporates tie rods, hinges, gimbals or pressure balancing bellows.

2. Spring Rate

In very low pressure applications the more significant force may be the spring rate which is expressed in pounds per inch of motion. Thus, as the pipe grows due to increasing temperature the bellows will resist compression by the force noted in the spring rate.

A comparison of pressure and force data to spring rate will show that it does not require very much line pressure for pressure thrust to be the dominant factor of the two in expansion joint applications.

Bellows formed from a metal cylinder in two steps.

Bellows length approximately one-third the length of original cylinder.

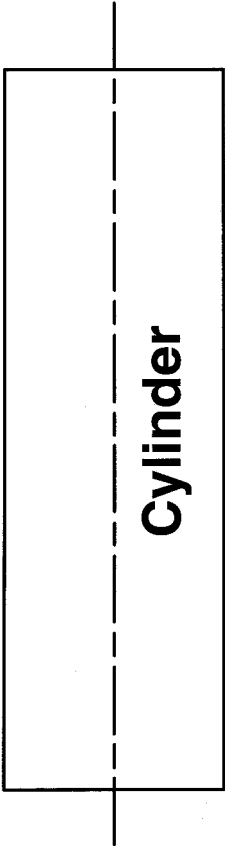

Step 1

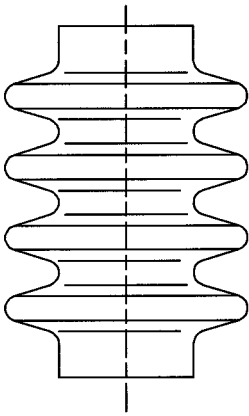

Step 2

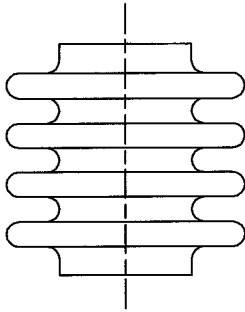

Adding flanges completes assembly of the single bellows expansion joint.

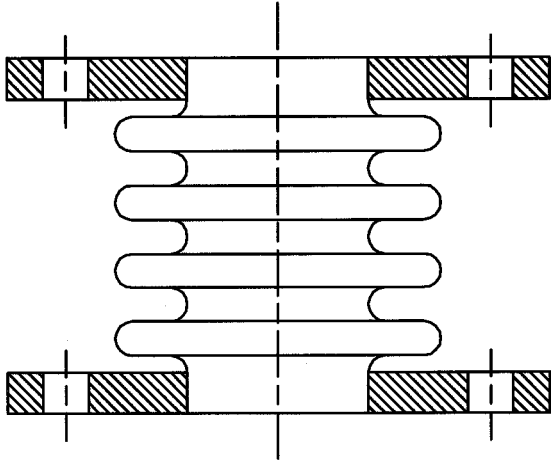

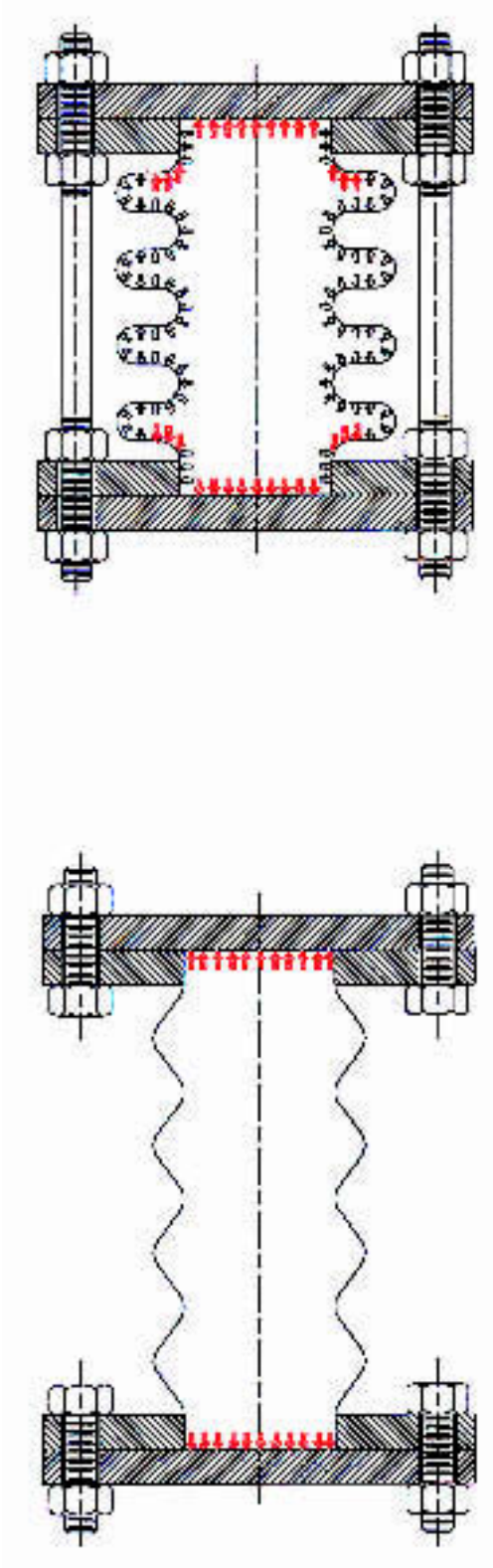

Unless restrained, the pressure thrust force will stretch the bellows of the expansion joint back into a cylinder.

Rods are installed temporarily to restrain the expansion joint during the hydrostatic test.

The arrows show the water exerting uniform pressure in all directions. The large red arrows show pressure pushing in directions that are not restrained by the bellows. This pressure creates a force that will elongate the bellows along its centerline. This force is called **Pressure Thrust**.

- “A” Bellows outside diameter
- “B” Effective area diameter
- “C” Bellows inside diameter

Effective

$$\text{Area} = \frac{\text{Outside diameter} + \text{Inside diameter}}{2}$$

Pressure Thrust Force (Lbs) = Effective Area (Sq. In.) x Pressure in the system (Lbs/Sq. In.).

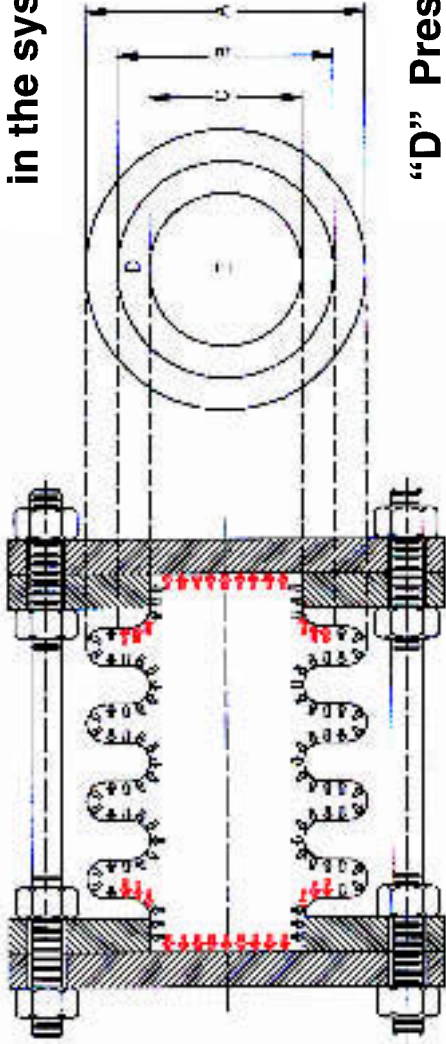

Expansion joint under hydrostatic test

- “D” Pressure thrust force pushing on the end convolutions of the bellows – up one-half the convolution height.
- “E” Pressure thrust force pushing on the blind flange or a change in direction of the piping.

Pressure thrust is always present in the piping system. It is reacted by the pipe itself.

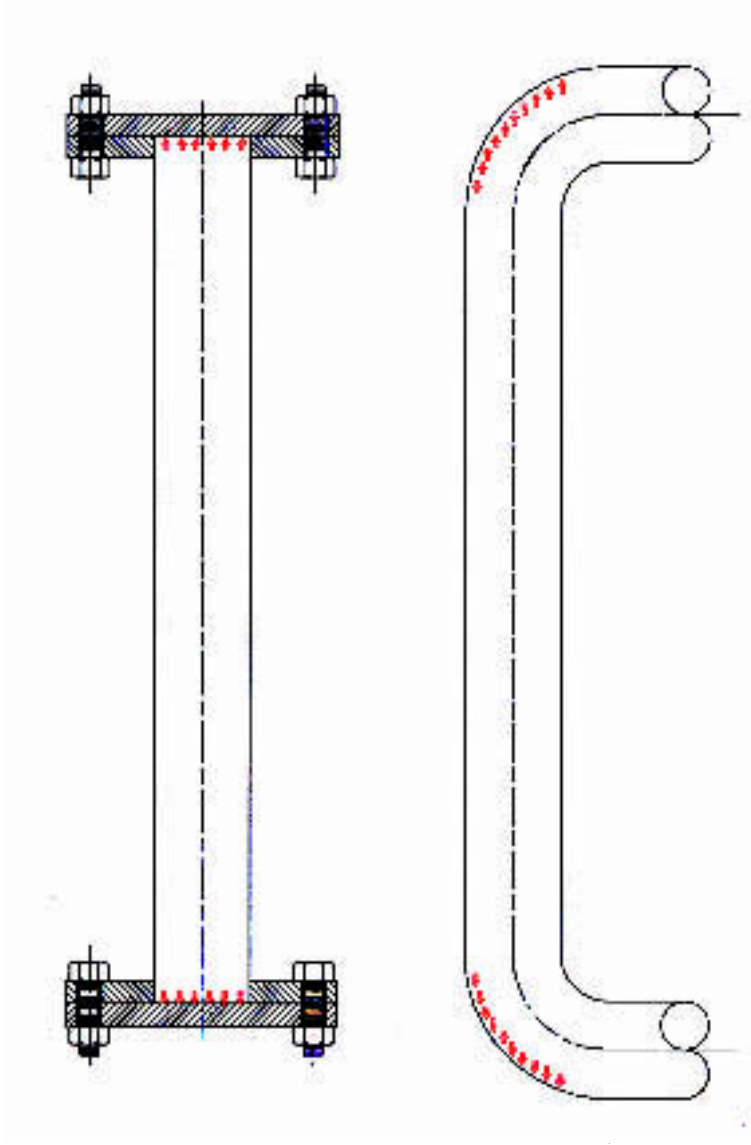

When a flexible bellows is installed in the pipe the pressure thrust will elongate the bellows unless the pipe is anchored.

Pressure thrust pushes the bellows apart at the end convolutions and pulls the bellows apart by pushing on the blind flanges.

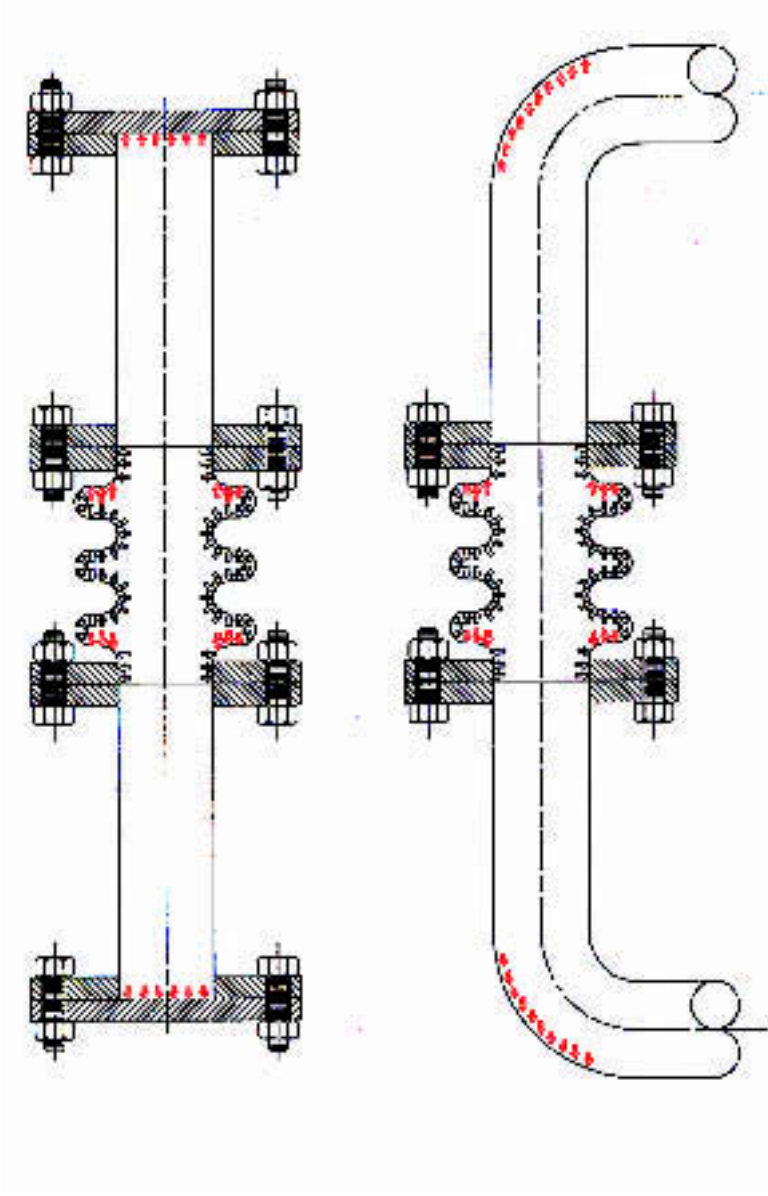

The pressure thrust force acts the same way when pushing on the elbows where the pipe changes direction.

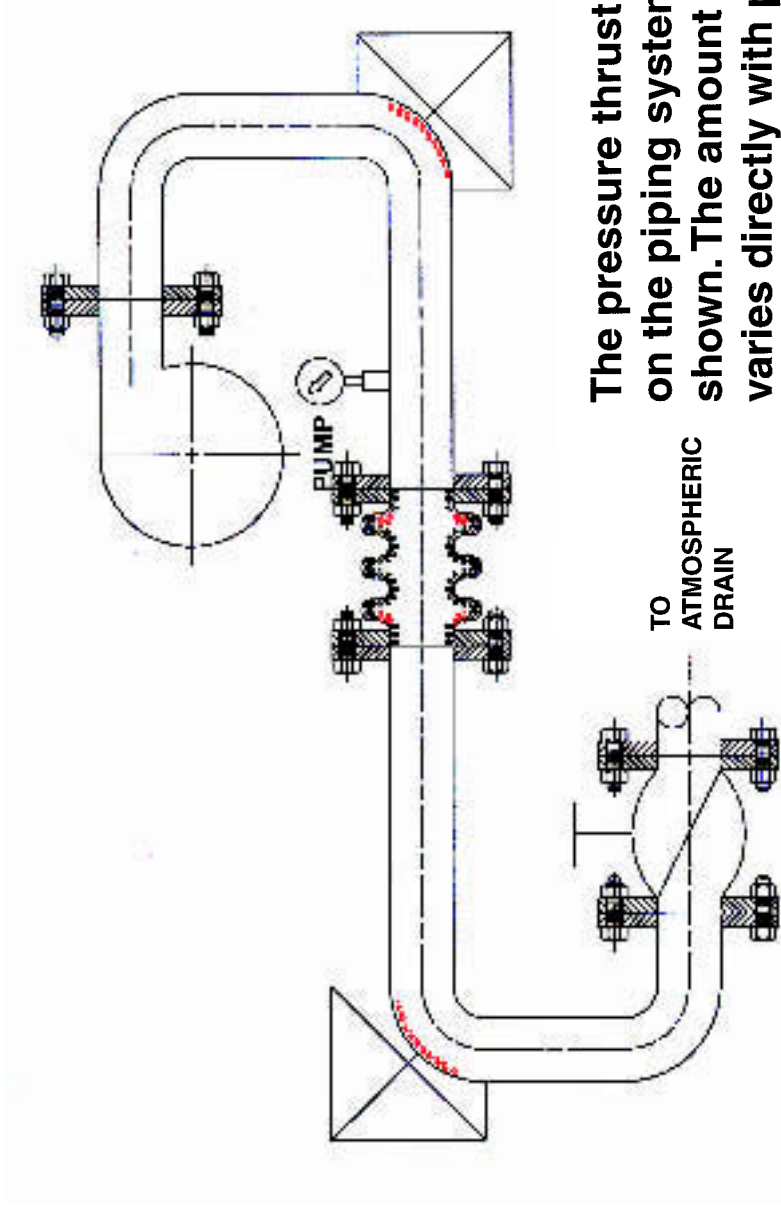

The pressure thrust force acts on the piping system as shown. The amount of force varies directly with pressure in the line. The pipe must be anchored to react to the pressure thrust force for the maximum pressure.

THE MOST FREQUENT APPLICATION

Expansion of a piping run due to an elevated operating temperature (axial motion).

Assumptions:

1. The piping system is properly supported and guided.
2. The weight of the piping system and the fluid being conveyed is carried by properly designed supports and hangers and is, therefore, not included.
3. Friction forces caused by guides, supports, and other hardware extraneous to the piping are zero.

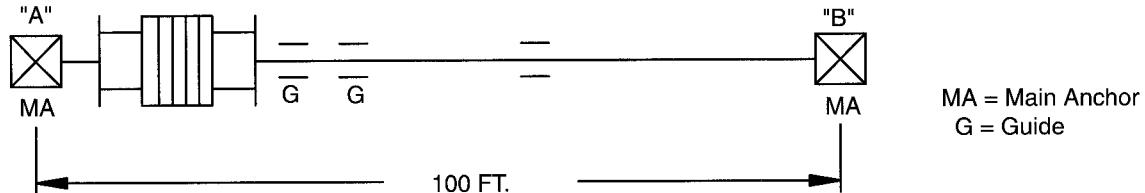

Problem: A straight run of 8" diameter carbon steel pipe is 100 feet long, and anchored at each end, is to operate at 125 psig saturated steam (350°F). The installation temperature is 70°F. A single bellows expansion joint is utilized to absorb the thermal growth of the pipe. Thermal growth is determined to be 2.26 inches.*

What are the forces acting on the anchors and guides?

A. Operating conditions.

B. Cold water hydrostatic test at 1.5 x design

Supply: Laminated bellows expansion joint 1501-167-3.0* *

Axial spring rate: 325 Lb./In. **

Effective area: 56.8 in.² ***

Solution A - Operating Conditions:

Forces acting on main anchor "A"

$$F_x = -F_s - F$$

$$F_x = -7100 - 734.5$$

$$F_x = -7834.5 \text{ Lbs.}$$

Where:

F_s = The static thrust due to internal pressure-Lbs

= (Effective Area) (Design Line Pressure)

= (56.8 In.²) (125 Lb./In.²)

= 7100 Lbs.

F = The force required to deflect the expansion joint

= (Spring Rate) (Deflection)

= (325 Lb./In.) (2.26 in.)

= 734.5 Lbs.

Forces acting on main anchor "B"

$$F_x = -F_s + F$$

$$F_x = -7100 + 734.5 = 7834.5 \text{ Lbs.}$$

Maximum lateral forces acting on the alignment guides are:

Force acting on main anchor x 0.15

Maximum lateral force = 7834.5 x 0.15

Maximum lateral force = 1175.2 Lbs.

* 3500 Series Catalog: Thermal Expansion of Pipe per 100 feet, carbon steel

** Series 1500 Laminated Bulletin, sheet 3

*** Series 1500 Laminated Bulletin, sheet 2

THE MOST FREQUENT APPLICATION (CONTINUED)

Solution B - Hydrostatic Test Conditions

Forces acting on main anchor "A"

$$F_x = -F_s - F$$

$$F_x = -10,650 - 0$$

$$F_x = -10,650 \text{ Lbs.}$$

Where:

F_s = The static thrust due to internal pressure-Lbs.

$$= (\text{Effective Area}) (\text{Design Line Pressure})$$

$$= (56.8 \text{ In.}^2) (125 \text{ Lb./In.}^2)$$

$$= 10,650 \text{ Lbs.}$$

$$= (\text{Spring Rate}) (\text{Deflection})$$

$$= (325 \text{ Lb./In.}) (0)$$

$$= 0 \text{ Lbs. (1)*}$$

Forces acting on main anchor "B"

$$F_x = -F_s + F$$

$$F_x = 10,650 + 0$$

$$F_x = 10,650 \text{ Lbs.}$$

Maximum lateral forces acting on the alignment guides are:

Force acting on main anchor x 0.15

$$\text{Maximum lateral force} = 10,650 \times 0.15$$

$$\text{Maximum lateral force} = 1597.5 \text{ Lbs.}$$

*(1) Since the Hydrostatic Test was conducted at ambient temperature (the same temperature at which the system was installed), the expansion joint has not been deflected and no axial spring force exerted.

The maximum forces are exerted during the Cold Water Hydrostatic Test. The main anchor must be designed to absorb the pressure thrust forces created by the test.

Since the maximum lateral forces that can act on the alignment guides are a function of the forces acting on the main anchors, they are also at a maximum during the Hydrostatic Test.

Recommended Use of Pipe Alignment Guides:

$$\text{1st Guide: } 4 \times D = 4 \times 8" = 32" = 2'8"$$

$$\text{2nd Guide: } 14 \times D = 14 \times 8" = 112" = 9'4"$$

$$\text{3rd Guide: From Graph} = 45' \text{ max spacing}$$

In using expansion joints to solve thermal expansion problems you must:

- Specify the correct expansion joint design.
- Provide main anchors that will absorb the maximum pressure thrust.
- Guide the piping properly.

If the pressure thrust forces are too great to be absorbed by main anchors, an expansion joint design which contains the pressure thrust must be used.

These are:

- Tied expansion joints (if the rods are always in tension)
- Pressure-balanced expansion joints
- Hinged expansion joints
- Gimballed expansion joints

THE MOST FREQUENT APPLICATION (CONTINUED)

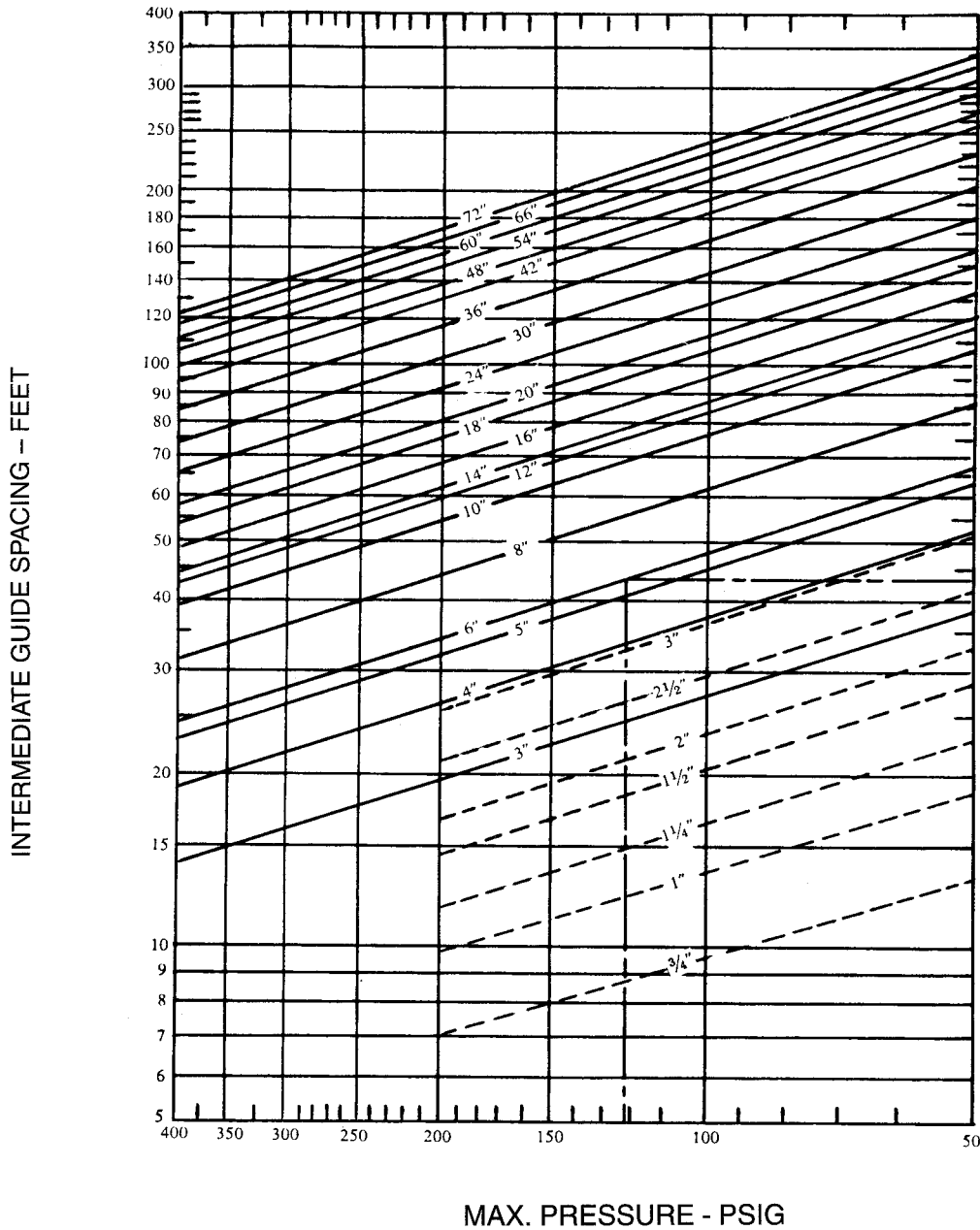
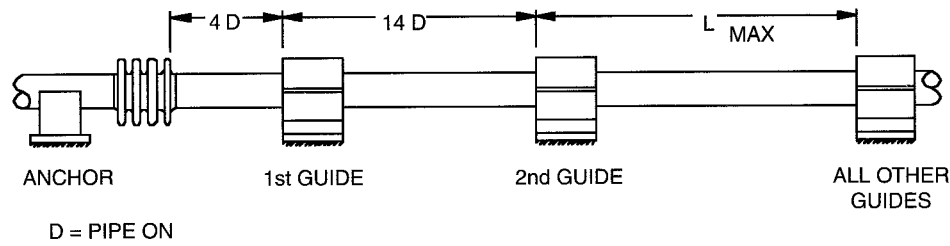

NOTE: First pipe guide must be located within a distance of four pipe diameters from the end of the bellows and the second guide must be located within a distance of fourteen pipe diameters from the first guide.

AXIAL MOVEMENT APPLICATIONS

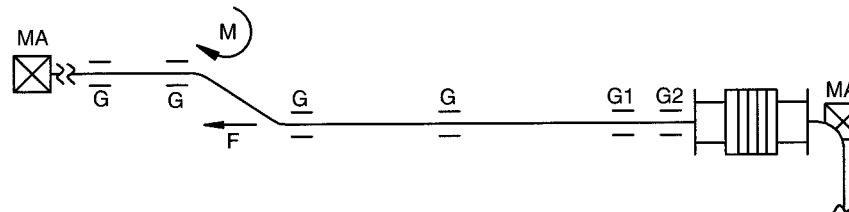
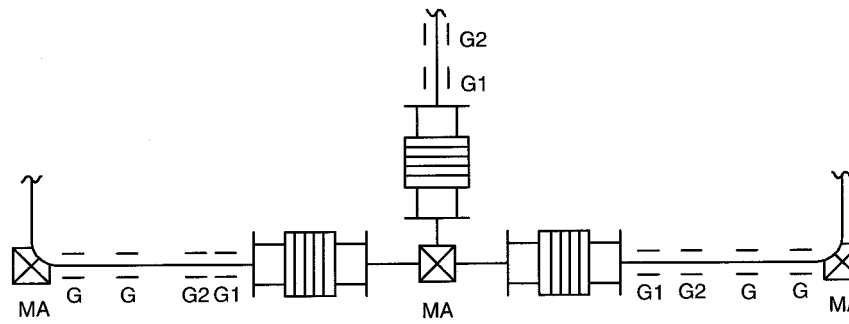
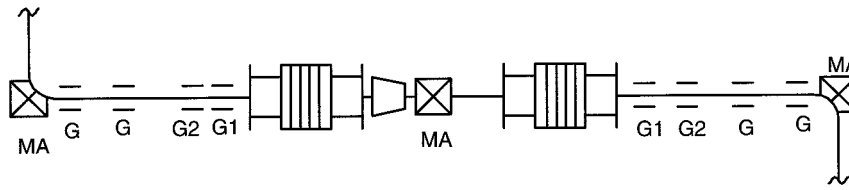
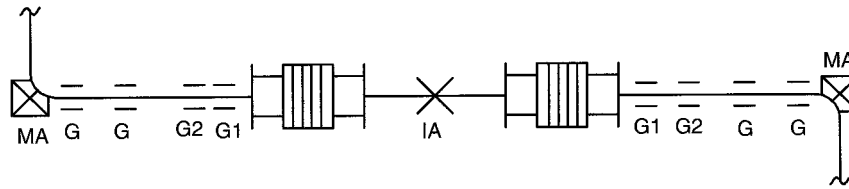
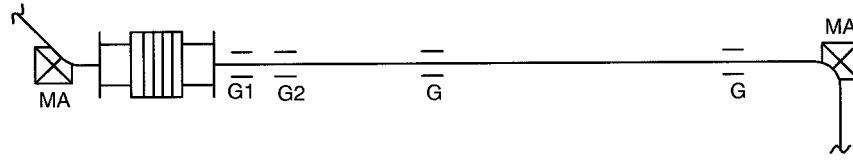

PRESSURE BALANCED EXPANSION JOINTS (AXIAL)

Design Concept:

- Pressure Thrust = Bellows Effective Area X Line Pressure
- Contain the pressure thrust within the expansion joint with "thrust rods."
- Use a second balancing bellows so that as the bellows taking the thermal expansion is compressed, the balancing bellows extends, keeping the thrust rods in tension and absorbing the pressure thrust within the expansion joint itself.
- The most frequently used design takes advantage of a change in the direction in the piping to position the balancing bellows.
- When there is no change in direction, an "in-line" pressure balanced design is used.

The in-line pressure balanced expansion joint uses a balancing bellows with twice the effective area of the motion bellows. This is because one-half of the balancing bellows area is in common with the motion bellows area. The area not in common generates the balancing force to apply to the thrust rods connected to the opposite ends of the expansion joint.

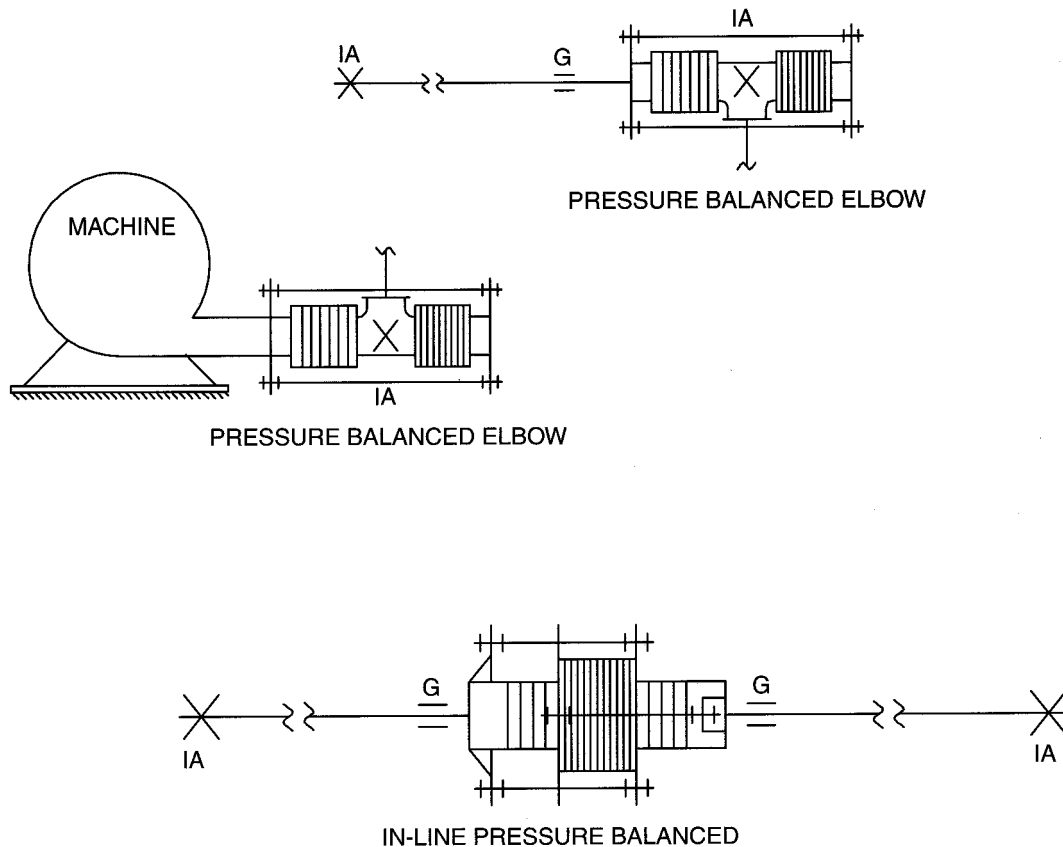

LATERAL MOVEMENT APPLICATIONS

Single expansion joints have very limited lateral capability.

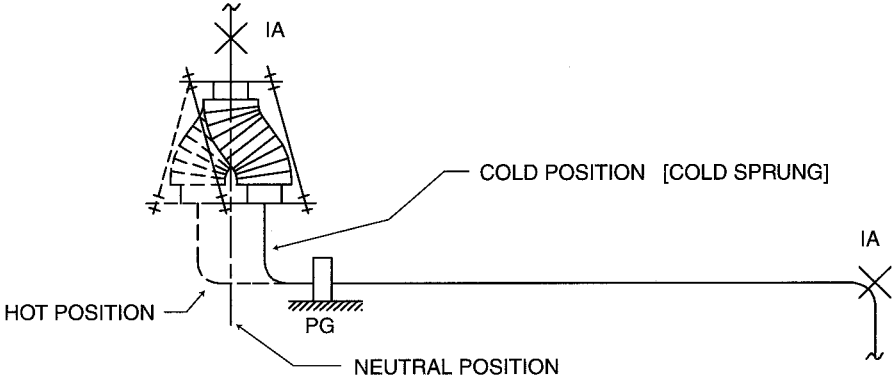
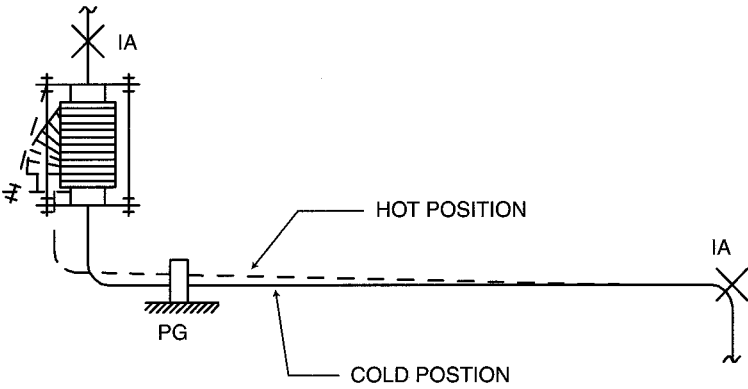
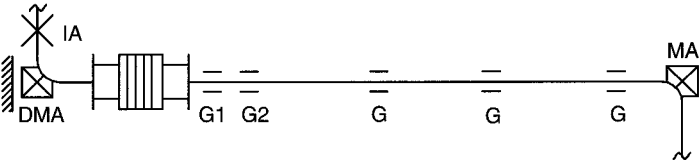

LATERAL MOVEMENT APPLICATIONS- UNIVERSAL TIED EXPANSION JOINTS

The universal expansion joint is capable of absorbing large lateral motions in any direction. The universal joint can absorb pressure thrust as long as it is not required to absorb external axial motion. External axial motions would compress the expansion joint, transferring the pressure thrust from the thrust rods to the connecting piping.

The universal expansion joint can absorb deflection in any plane.

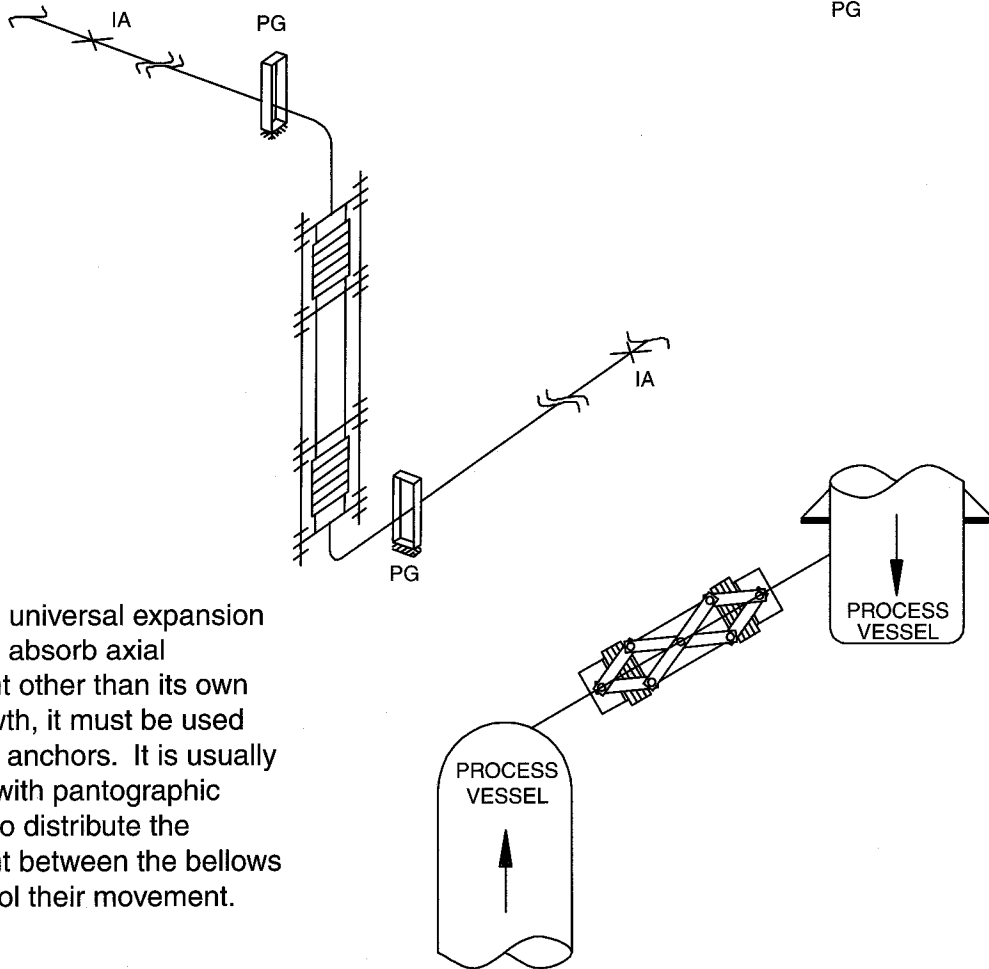
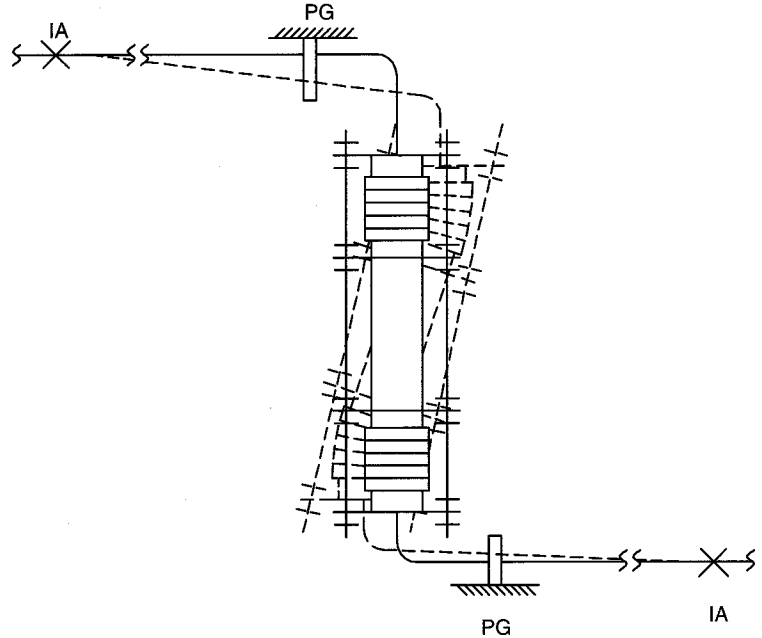

When the universal expansion joint must absorb axial movement other than its own axial growth, it must be used with main anchors. It is usually supplied with pantographic linkages to distribute the movement between the bellows and control their movement.

PRESSURE BALANCED EXPANSION JOINTS (LATERAL)

Examples where axial and a small amount of lateral motion is absorbed.

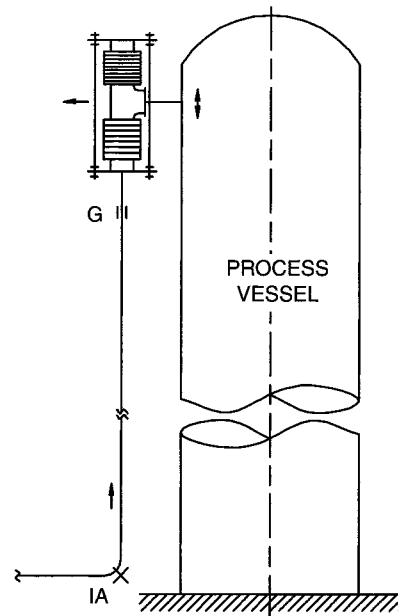
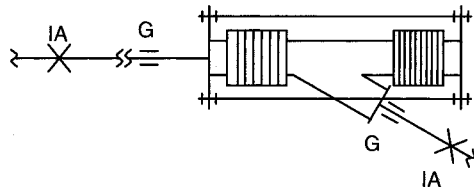
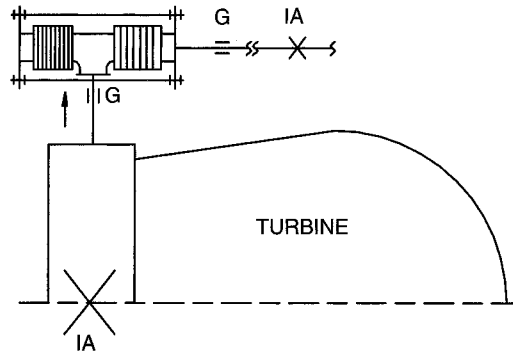

For large amounts of lateral motion combined with axial motion, a pressure-balanced universal expansion joint must be used.

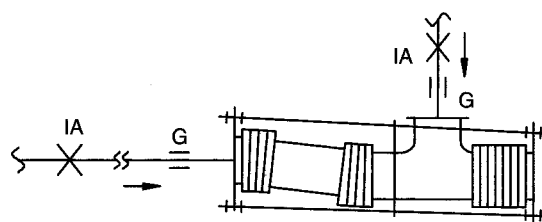

HINGED EXPANSION JOINTS

- Used in sets of two or three to absorb lateral deflection in one or more directions in a single-plane piping system.
- Each expansion joint is restricted to pure angular rotation by its hinges.
- When the joints are separated by a segment of piping, they will act like a universal expansion joint in a single-plane application.
- Hinged expansion joints:
 - Are compact in size
 - Have great rigidity and strength
 - Can be used in irregular and complex piping systems
 - Can transmit loads.

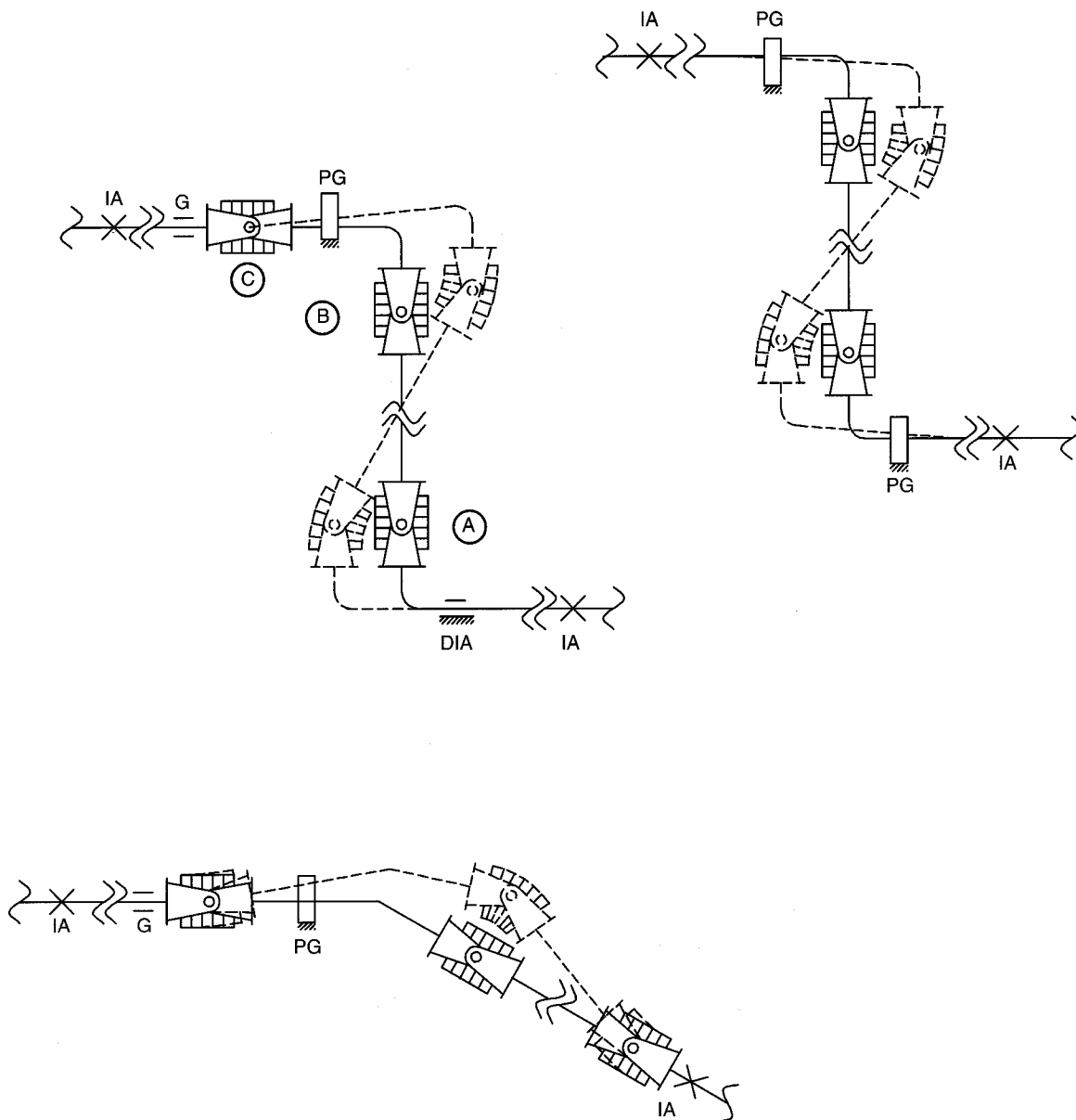

HINGED EXPANSION JOINTS (CONTINUED)

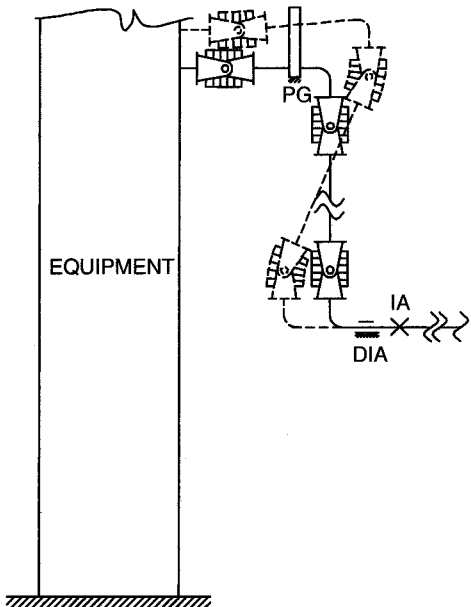
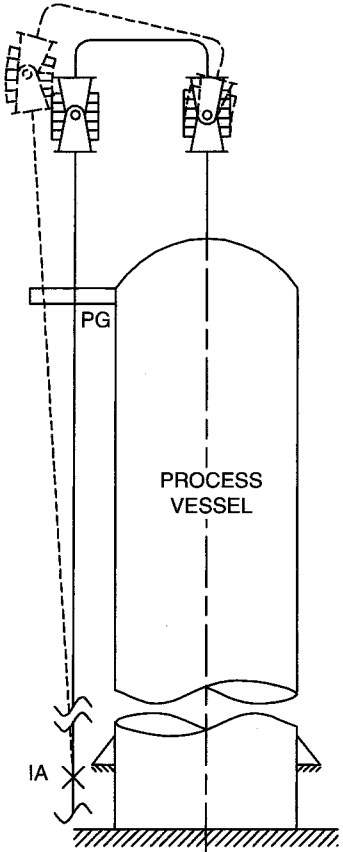

GIMBAL EXPANSION JOINTS

- Used in sets of two (occasionally more) to absorb lateral deflection in multi-plane systems.
- Advantages are similar to hinged expansion joint systems except they are not restricted to single plane systems.

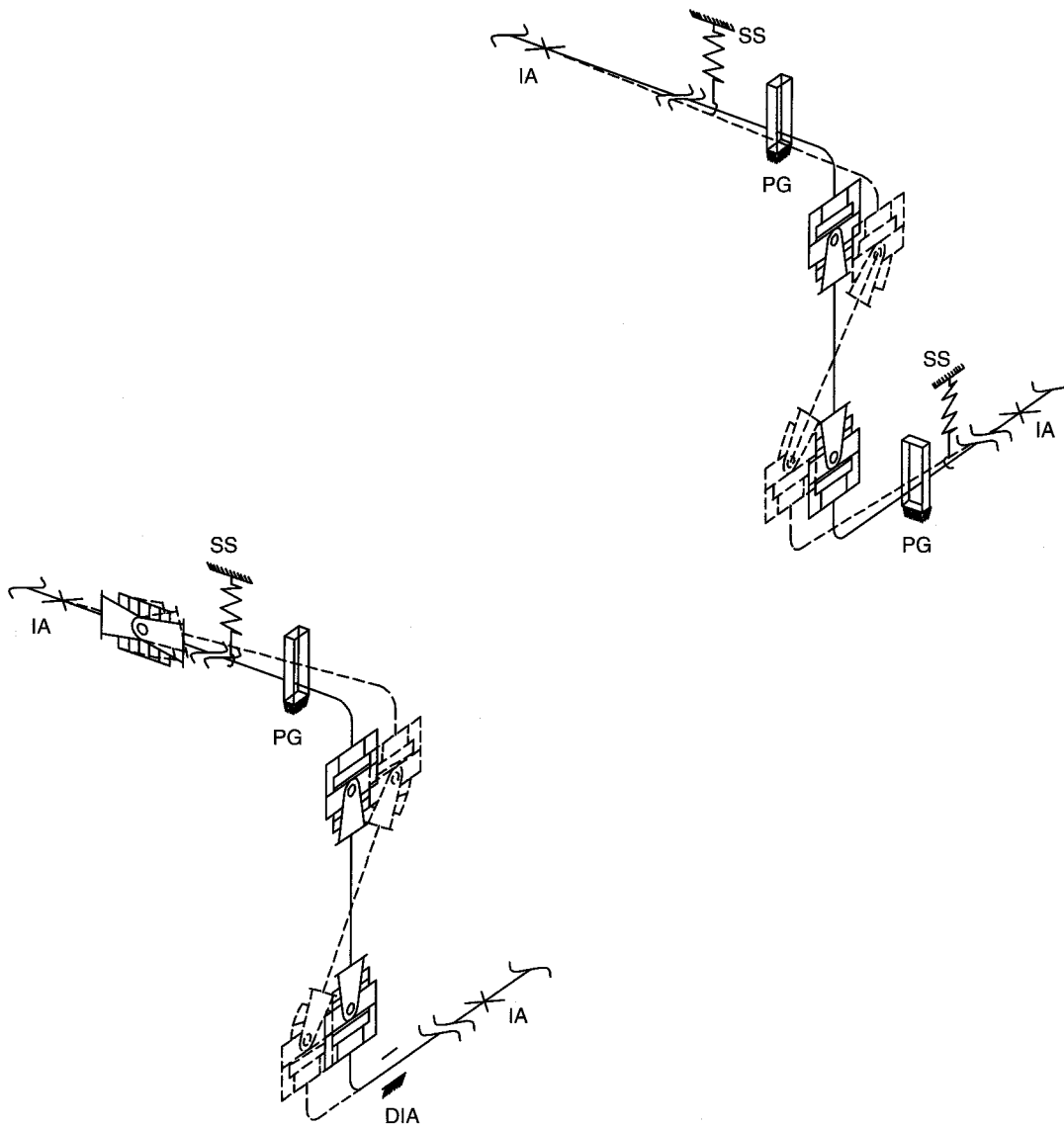

DUCTWORK EXPANSION JOINTS

- Usually low pressure applications
- Frequently measured in inches of water column.

ROUND EXPANSION JOINTS

- Same characteristics as round expansion joints in pressure piping applications.
- In large diameter applications spring forces are more significant compared to pressure thrust forces; especially in combustion gas applications (inches of water column pressure).
- Expansion joints do not absorb any lateral movement because they are too stiff (very high lateral spring rates).
- If lateral movement is required must use universal design. (Two bellows with a centerspool between them so they each take angular motion).

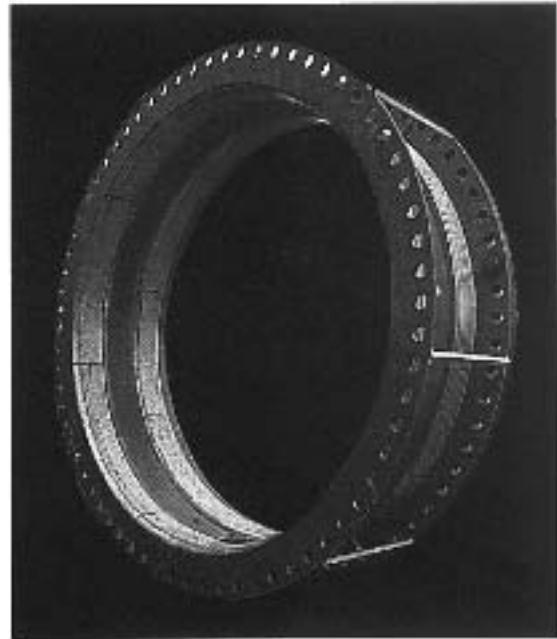
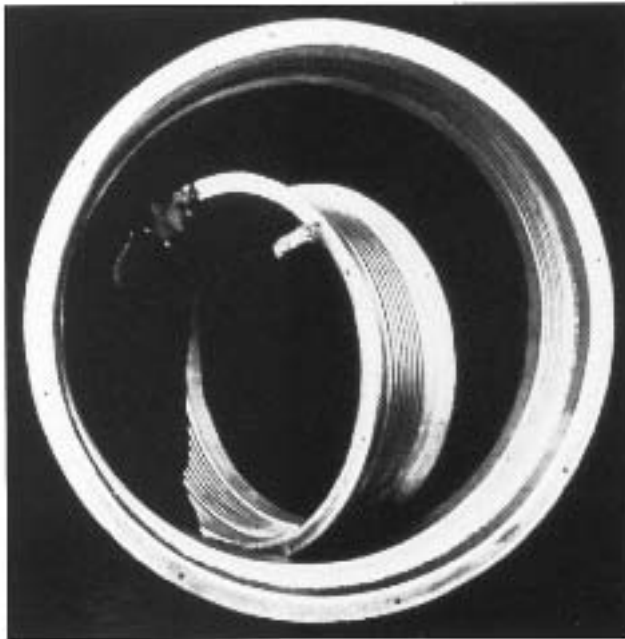

RECTANGULAR EXPANSION JOINTS

- Similar design procedures to the circular expansion joints.
- Major difference is the lateral asymmetrical flexing created by the difference in the length of the sides.
- As the difference in length increases, the joint becomes more resistant to lateral deflection parallel to the long side.

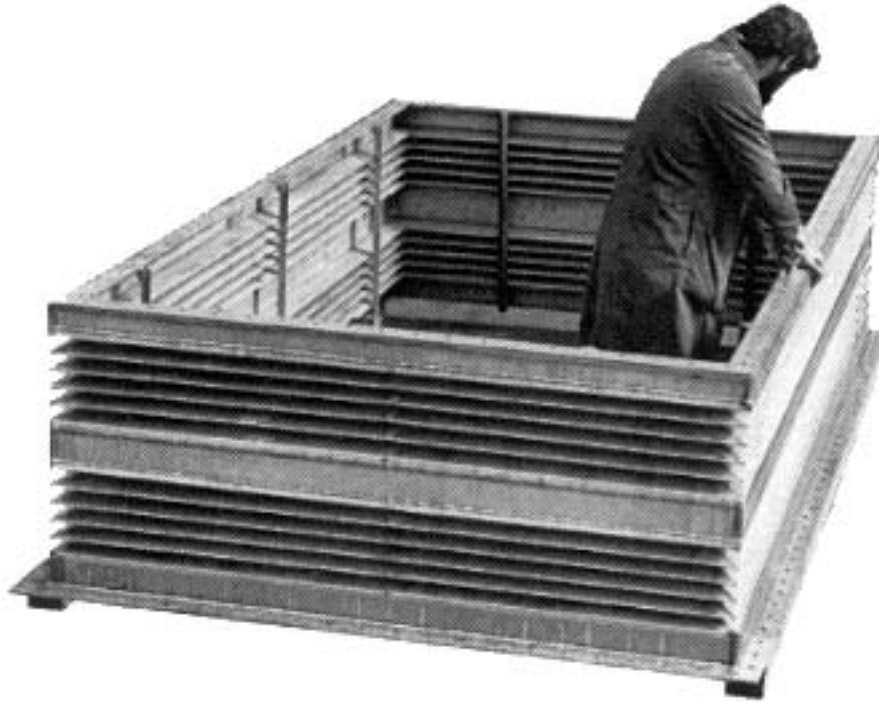

Dual rectangular expansion joint made from all Inconel 625 material

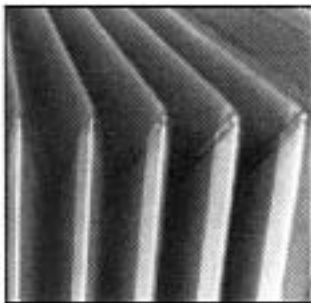

Mitre Corner

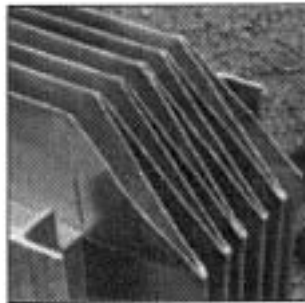

Camera or Bevel Corner

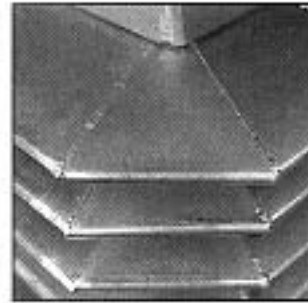

Double Mitre Corner

SINGLE PLY VS LAMINATED BELLOWS

- **Single Ply**

Pipe Size = 10"
 Corrugation Depth = 0.6"
 Corrugation Pitch = 0.5"
 Material Thickness = .018"

- **Laminated**

Pipe Size = 10"
 Corrugation Depth = 0.6"
 Corrugation Pitch = 0.5"
 Material Thickness is
 3 thicknesses of .012" = .036"

- The reduced thickness of the laminations results in lower bending stresses due to axial motion increasing the life of the bellows. The laminated bellows have lower spring rates and a greater cycle life.

BOTH BELLOWS ARE DESIGNED FOR THE SAME OPERATING CONDITIONS

Design Features

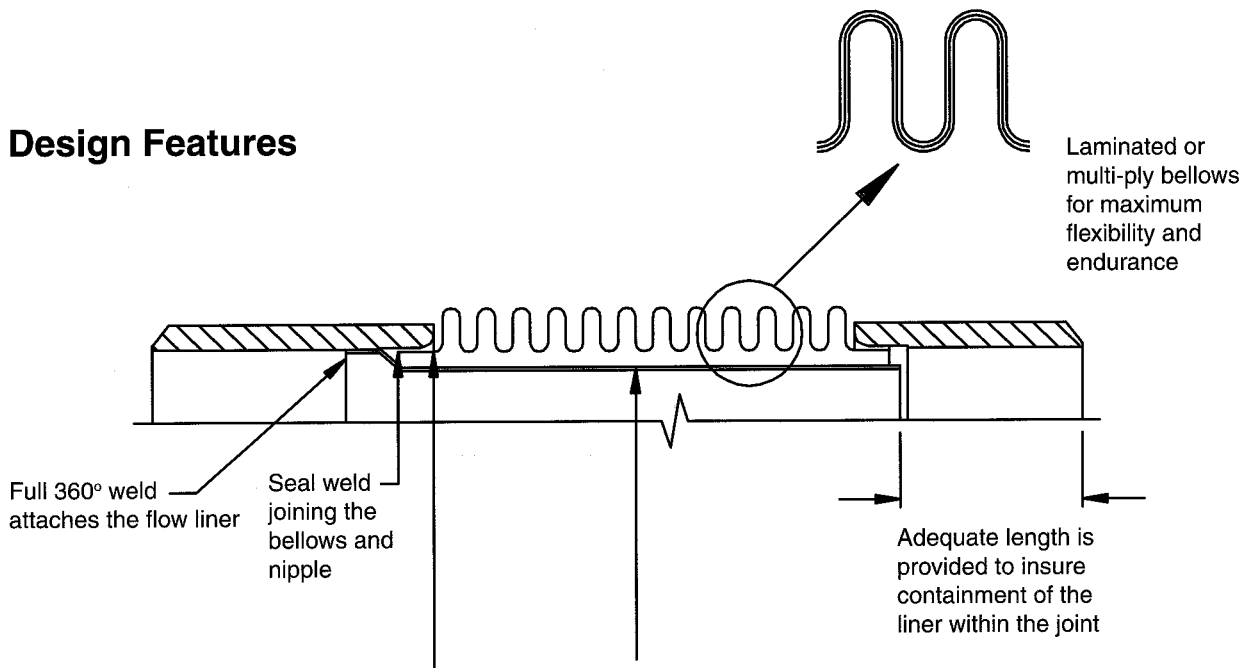

The bellows is inserted and sized to mate with smooth machined surfaces in the nipple. The nipple supports the bellows neck, a critical stress zone. Major stresses are eliminated in the bellows and the seal weld joining it to the nipple. Standard nipple material is carbon steel pipe.

The stainless steel flow liner isolates the bellows from vibration and erosion generated by turbulence. Although the liner is not designed to contract or guide the bellows, it does add safety by resisting squirm or instability if over-pressure occurs. Clearance is provided to allow the specified lateral offset. External labels indicated the flow direction.

LOW CORRUGATION VS HIGH CORRUGATION

HIGH CORRUGATION

- Pipe Size = 6.0"
- Corrugation Depth = 2.5"
- Corrugation Pitch = 2.3"
- Material Thickness = 0.125"
- Pressure Rating = 50 psi*
- * To go to higher pressures, must use reinforcing rings.
- The net effect is the rings form the structure and the bellows form the seal.

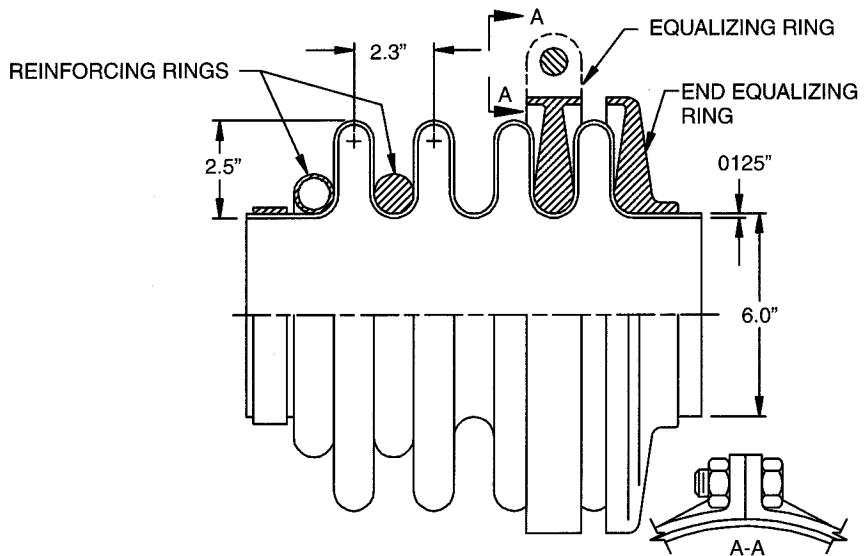

LOW CORRUGATION

- Pipe Size = 6.0"
- Corrugation Depth = 0.6"
- Corrugation Pitch = 0.63"
- Material Thickness = .018"
- Pressure Rating = 150 psi
- Test Pressure = 225 psi
- A margin of approximately 4 to 1 for burst pressure

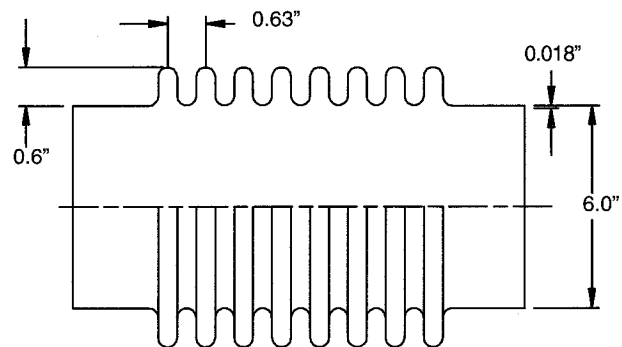

By reducing the corrugation height and the pitch, we limit the pressure stresses on the corrugation cross-section. In effect, the designer is utilizing the corrugating to increase the equivalent thickness of the bellows material — the same technique used for corrugated siding and roofing.

Features:

- No ring reinforcement required
- Lower rod and hinge hardware costs
- Smaller effective area reduces anchoring costs
- Extension allowance normally eliminates precompression at installation site
- Lighter weights reduce shipping costs and simplify installation

INTERNALLY PRESSURIZED BELLOWS BELLOWS STABILITY

- An internally pressurized expansion joint will eventually buckle at some internal pressure loading. This buckling is called squirm. Squirm is detrimental to bellows performance in that it can greatly reduce both fatigue life and pressure capacity.
- Every internally pressurized bellows will squirm if the pressure is increased to a high enough level. For a given diameter bellows, the longer the convoluted length the lower the pressure required to cause squirm.
- For a given pressure, the larger the diameter, the longer the convoluted length can be before the bellows will squirm. Therefore, the smaller the diameter the shorter the convoluted length and the less movement the bellows can absorb.

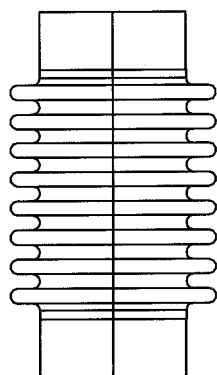

NORMAL

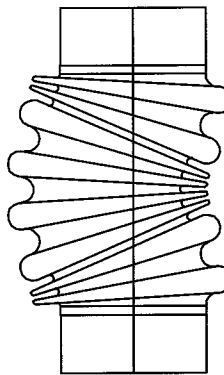

SQUIRM

EXTERNALLY PRESSURIZED BELLOWS BELLOWS STABILITY

- External pressure does not produce squirm no matter how long the convoluted length.
- Expansion joints designed with externally pressurized bellows can accommodate long axial movements even in small diameters.

EXTERNALLY PRESSURIZED GUIDED EXPANSION JOINT

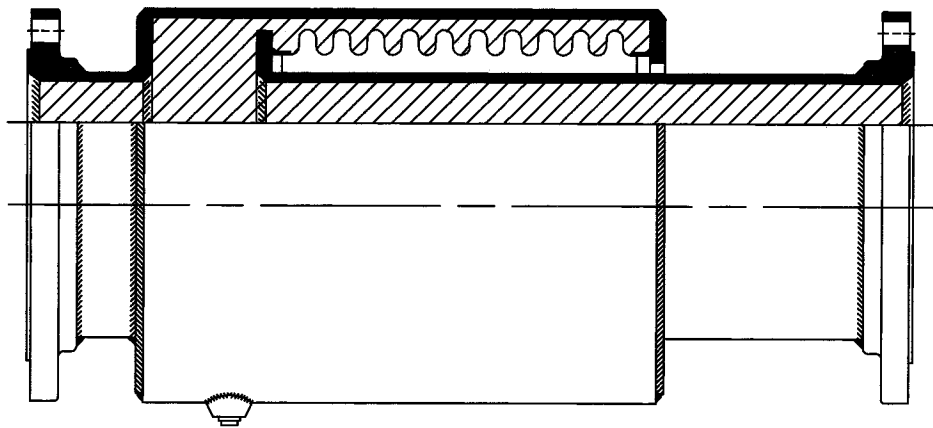

CUT-AWAY SIDE VIEW

- Suitable for virtually any axial movement.
- Bellows element is completely enclosed to preclude external damage, internal contact with the flow, and containment of the media in the event of bellows rupture.
- External pressurization of the bellows eliminates squirm or instability — even if over-pressurization occurs.
- Internal guides and stops insure alignment and prevent over-travel of the bellows.
- External guiding is necessary but minimized by integral guides in the joint.

EXTERNALLY PRESSURIZED EXPANSION JOINT APPLICATION

Expansion of a piping run due to an elevated operating temperature (axial motion).

Assumptions:

1. The piping system is properly supported and guided.
2. The weight of the piping system and the fluid being conveyed is carried by properly designed supports and hangers and is, therefore, not included.
3. Friction forces caused by guides, supports, and other hardware extraneous to the piping are zero.

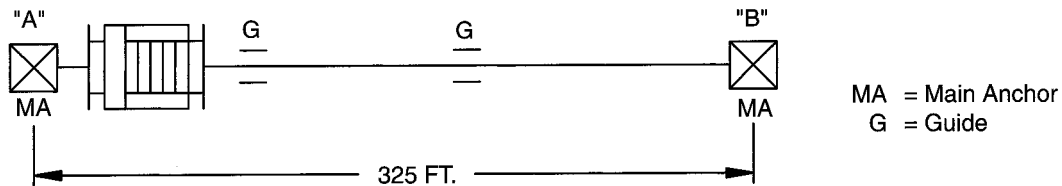

Problem: A straight run of 8" diameter carbon steel pipe is 325 feet long, and anchored at each end, is to operate at 125 psig saturated steam (350°F). The installation temperature is 70°F. A single bellows expansion joint is utilized to absorb the thermal growth of the pipe. Thermal growth is determined to be 7.35 inches.*

What are the forces acting on the anchors and guides?

- A. Operating conditions
- B. Cold water hydrostatic test at 1.5 x design

Supply: SERIES 3500 EXTERNALLY PRESSURIZED 3501-167-8
 Axial spring rate: 326 Lb./In.* *
 Effective area: 80.5 In.² * * *

Solution A - Operating Conditions:

Forces acting on main anchor "A"

$$F_x = -F_s - F$$

$$F_x = -10064 - 2396$$

$$F_x = -12460 \text{ Lbs.}$$

Where:

F_s = The static thrust due to internal pressure-Lbs.
 = (Effective Area) (Design Line Pressure)
 = (80.5 In.²) (125 Lb./In.²)
 = 10064 Lbs.

F = The force required to deflect the expansion joint
 = (Spring Rate) (Deflection)
 = (326 Lb./In.) (7.35 In.)
 = 2396 Lbs.

Forces acting on main anchor "B"

$$F_x = F_s + F$$

$$F_x = 10064 + 2396 = 12460 \text{ Lbs.}$$

Maximum lateral forces acting on the alignment guides are:

$$\text{Force acting on main anchor} \times 0.15$$

$$\text{Maximum lateral force} = 12460 \times 0.15$$

$$\text{Maximum lateral force} = 1869 \text{ Lbs.}$$

* 3500 Series Catalog: "Thermal Expansion of Pipe" per 100 feet, carbon and wrought iron
 ** SERIES 3500 CATG 574 PAGE 5
 *** SERIES 3500 CATG 574 PAGE 4

EXTERNALLY PRESSURIZED EXPANSION JOINT APPLICATION (CONTINUED)

Solution B - Hydrostatic Test Conditions

Forces acting on main anchor "A"

$$F_x = -F_s - F$$

$$F_x = -15094 - 0$$

$$F_x = -15094 \text{ Lbs.}$$

Where:

F_s = The static thrust due to internal pressure-Lbs.

= (Effective Area) (Design Line Pressure)

= (80.5 In.²) (187.5 Lb./In.²)

= 15094 Lbs.

F = (Spring Rate) (Deflection)

= (326 Lb./In.) (0)

= 0 Lbs. (1)*

Forces acting on main anchor "B"

$$F_x = F_s + F$$

$$F_x = 15094 + 0$$

$$F_x = 15094 \text{ Lbs.}$$

Maximum lateral forces acting on the alignment guides are:

Force acting on main anchor x 0.15

Maximum lateral force = 15094 x 0.15

Maximum lateral force = 2264 Lbs.

*(1) Since the Hydrostatic Test was conducted at ambient temperature (the same temperature at which the system was installed), the expansion joint has not been deflected and no axial spring force exerted.

The maximum forces are exerted during the Cold Water Hydrostatic Test. The main anchor must be designed to absorb the pressure thrust forces created by the test.

Since the maximum lateral forces that can act on the alignment guides are a function of the forces acting on the main anchors, they are also at a maximum during the Hydrostatic Test.

Recommended Use of Pipe Alignment Guides:

1st Guide: $14 \times D = 14 \times 8 = 112" = 9'4"$

2nd Guide: From Graph = 45' max spacing

In using expansion joints to solve thermal expansion problems you must:

- Specify the correct expansion joint design
- Provide main anchors that will absorb the maximum pressure thrust.
- Guide the piping properly.

If the pressure thrust forces are too great to be absorbed by main anchors, an expansion joint design which contains the pressure thrust must be used.

These are:

- Tied expansion joints (if the rods are always in tension)
- Pressure-balanced expansion joints
- Hinged expansion joints
- Gimbal expansion joints

PRESSURE BALANCED EXTERNALLY PRESSURIZED GUIDED EXPANSION JOINT

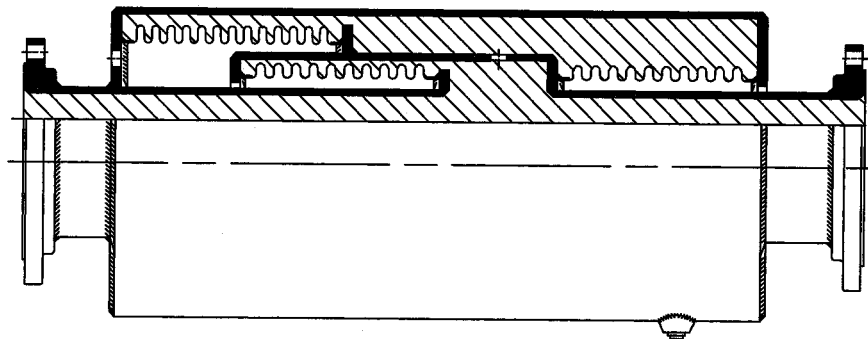
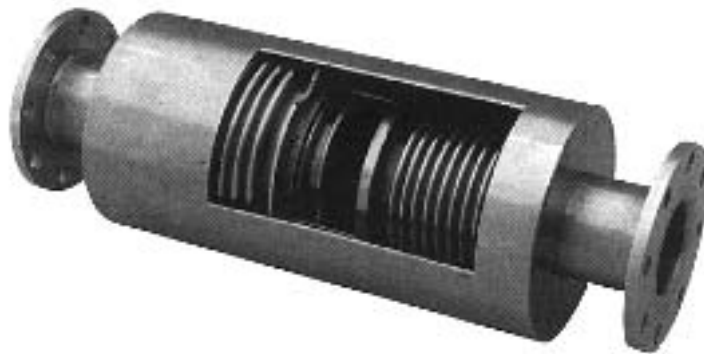

- Internally reacts pressure thrust eliminating the requirement for main anchors.
Note: Intermediate anchors are required.
- Suitable for virtually any axial movement.
- Bellows element is completely enclosed to preclude external damage, internal contact with the flow, and containment of the media in the event of bellows rupture.
- External pressurization of the bellows eliminates squirm or instability — even if over-pressurization occurs.
- Internal guides and stops insure alignment and prevent over-travel of the bellows.
- External guiding is necessary but minimized by integral guides in the joint and the absence of pressure thrust force on the system.

PRESSURE BALANCED EXTERNALLY PRESSURIZED EXPANSION JOINT APPLICATION

Expansion of a piping run due to an elevated operating temperature (axial motion).

Assumptions:

1. The piping system is properly supported and guided.
2. The weight of the piping system and the fluid being conveyed is carried by properly designed supports and hangers and is, therefore, not included.
3. Friction forces caused by guides, supports, and other hardware extraneous to the piping are zero.

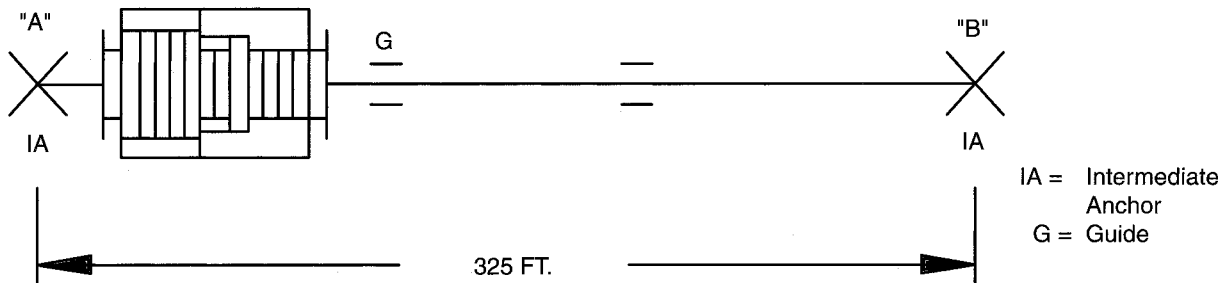

Problem: A straight run of 8" diameter carbon steel pipe is 325 feet long, and anchored at each end, is to operate at 125 psig saturated steam (350°F). The installation temperature is 70°F. A pressure balanced single bellows expansion joint is utilized to absorb the thermal growth of the pipe. Thermal growth is determined to be 7.35 inches.*

What are the forces acting on the anchors and guides?

- A. Operating conditions
- B. Cold water hydrostatic test at 1.5 x design

Supply: SERIES 3500 EXTERNALLY PRESSURIZED 3501PB-167-8
Axial spring rate: 786 Lb./In.**

Solution A - Operating Conditions:

Forces acting on main anchor "A"
 $F_x = 5777$ Lbs.

Where:

F = The force required to deflect the expansion joint
 = (Spring Rate) (Deflection)
 = (786 Lb./In.) (7.35 In.)
 = 5777 Lbs.

Forces acting on main anchor "B"
 $F_x = 5777$ Lbs.

Maximum lateral forces acting on the alignment guides are:

Force acting on main anchor x 0.15
 Maximum lateral force = 5777×0.15
 Maximum lateral force = 867×0.15

* 3500 Series Catalog: "Thermal Expansion of Pipe" per 100 feet, carbon and wrought iron

** SERIES 3500 CATG 574 PAGE 7

PRESSURE BALANCED EXTERNALLY PRESSURIZED EXPANSION JOINT APPLICATION (CONTINUED)

Solution B - Hydrostatic Test Conditions

Forces acting on main anchor "A"

$F_x = 0$ Lbs.

Where:

= (Spring Rate) (Deflection)

= (5777 Lb./In.) (0)

= 0 Lbs. (1)*

Forces acting on main anchor "B"

$F_x = 0$ Lbs.

Maximum lateral forces acting on the alignment guides are:

Force acting on main anchor x 0.15

Maximum lateral force = 0×0.15

Maximum lateral force = 0 Lbs.

*(1) Since the Hydrostatic Test was conducted at ambient temperature (the same temperature at which the system was installed), the expansion joint has not been deflected and no axial spring force exerted.

The maximum forces are exerted during operating conditions.

Recommended Use of Pipe Alignment Guides:

1st Guide: $14 \times D = 14 \times 8 = 112" = 9'4"$

Additional Guides = 77' max spacing

In using expansion joints to solve thermal expansion problems you must:

- Specify the correct expansion joint design
- Guide the piping properly.

KEY SYMBOLS USED

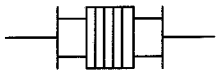

SINGLE EXPANSION JOINT

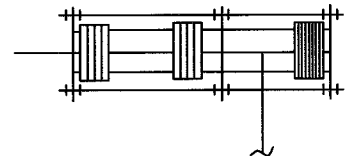

UNIVERSAL PRESSURE BALANCED EXPANSION JOINT

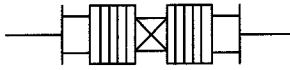

DOUBLE EXPANSION JOINT WITH INTERMEDIATE ANCHOR

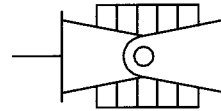

HINGED EXPANSION JOINT

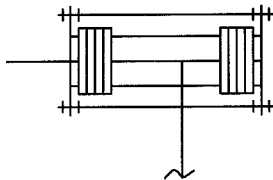

PRESSURE BALANCED EXPANSION JOINT

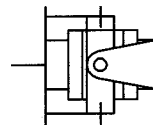

GIMBAL EXPANSION JOINT

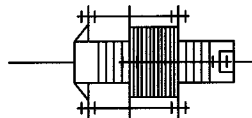

IN-LINE PRESSURE BALANCED EXPANSION JOINT

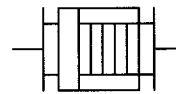

EXTERNALLY PRESSURIZED EXPANSION JOINT

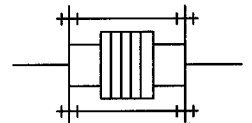

SINGLE EXPANSION JOINT WITH TIE RODS

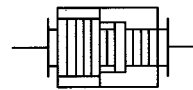

PRESSURE BALANCED EXTERNALLY PRESSURIZED EXPANSION JOINT

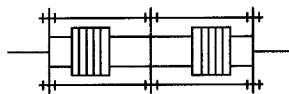

UNIVERSAL EXPANSION JOINT WITH OVERALL TIE RODS

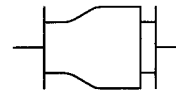

PACKED EXPANSION JOINT

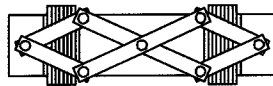

UNIVERSAL EXPANSION JOINT WITH PANTOGRAPHIC LINKAGES

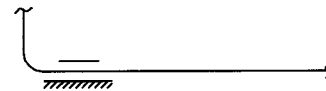

DIA DIRECTIONAL INTERMEDIATE ANCHOR WITH GUIDE

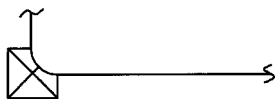

MA MAIN ANCHOR

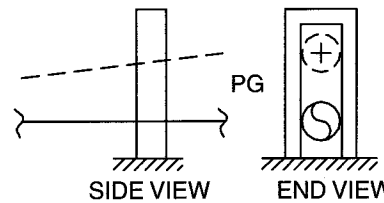

PLANAR PIPE ALIGNMENT GUIDE

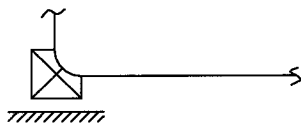

DMA DIRECTIONAL MAIN ANCHOR

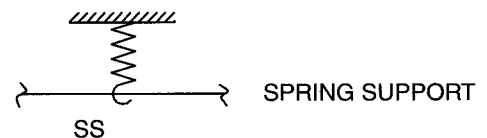

SS SPRING SUPPORT

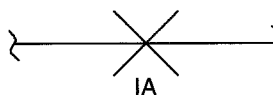

IA INTERMEDIATE ANCHOR

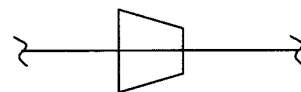

PIPE REDUCER

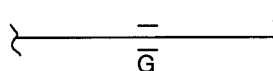

G PIPE ALIGNMENT GUIDE



Hyspan

Expansion Joint Applications

MAIN ANCHOR PIPING SYSTEMS
INTERMEDIATE ANCHOR PIPING SYSTEMS
HANGER SUPPORTED SYSTEMS
EQUIPMENT VIBRATION ISOLATION

MAIN ANCHOR PIPING SYSTEM

Series 1500 Internally Pressurized Expansion Joint

Series 9500 Pipe Alignment Guide

For movement up to 2.4".



SERIES 1500



SERIES 9500

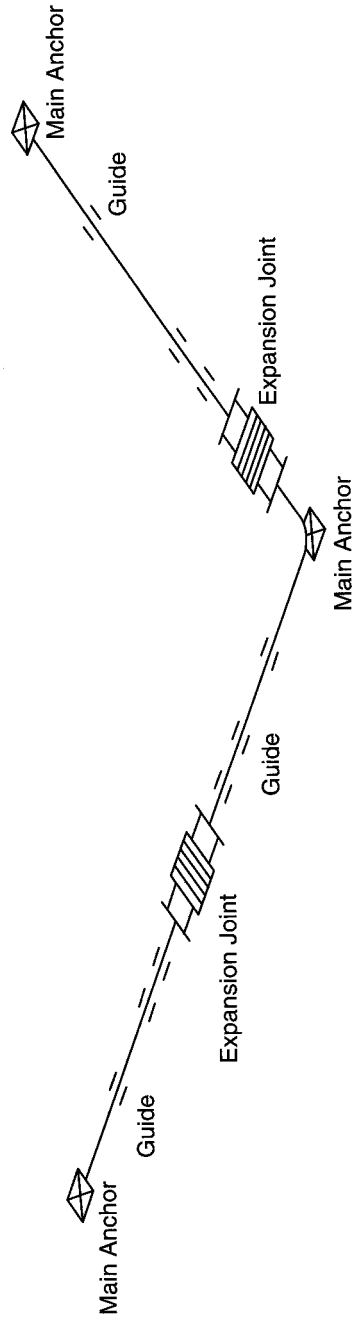

MAIN ANCHOR PIPING SYSTEM

Series 1500 Dual Internally Pressurized Expansion Joint

Series 9500 Pipe Alignment Guide

By using a dual unit with an intermediate anchor at the center of a long run of pipe, movement up to 4.8" can be handled by the expansion joint.



SERIES 9500



SERIES 3500

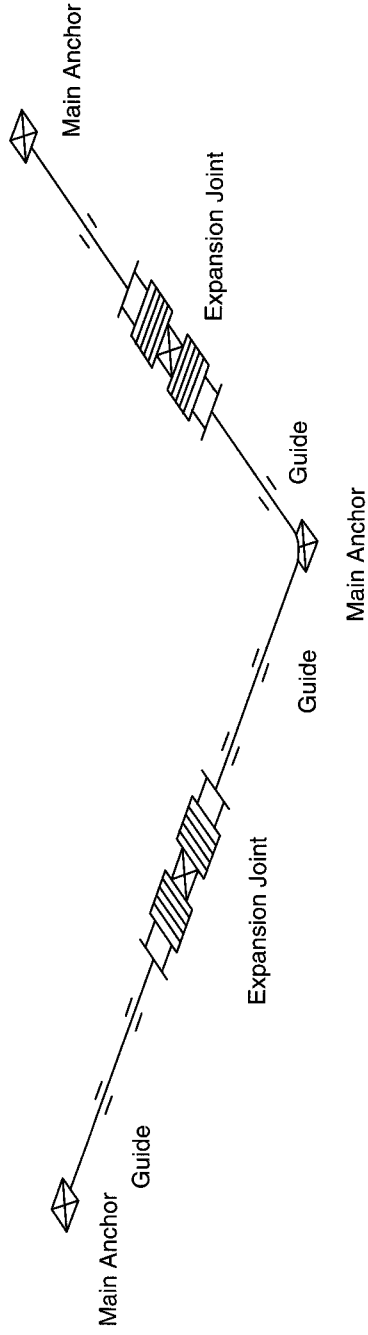

MAIN ANCHOR PIPING SYSTEM

- Series 3500 Externally Pressurized Internally Externally Guided Expansion Joint
 - Series 9500 Pipe Alignment Guide
- For movement up to 8"



SERIES 1500



SERIES 9500

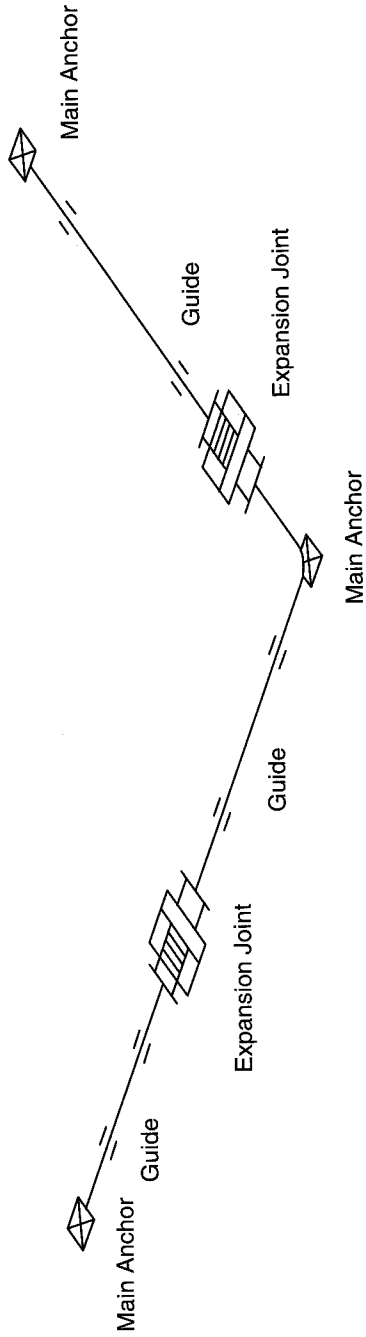

MAIN ANCHOR PIPING SYSTEM

Series 3500 Dual Externally Pressurized Internally Externally Guided Expansion Joint
Series 9500 Pipe Alignment Guide

By using a dual unit with an intermediate anchor at the center of a long run of pipe, movement up to 16" can be handled by the expansion joint.



SERIES 3500



SERIES 9500

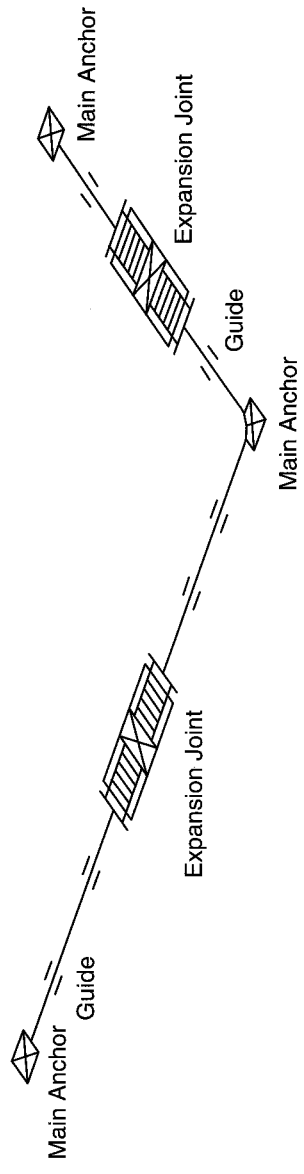

MAIN ANCHOR PIPING SYSTEM

Series 8500 Externally Pressurized Expansion Compensator
Series 9500 Pipe Alignment Guide
Compensators are used in piping or tubing systems to absorb thermal expansion.



SERIES 9500



SERIES 8500

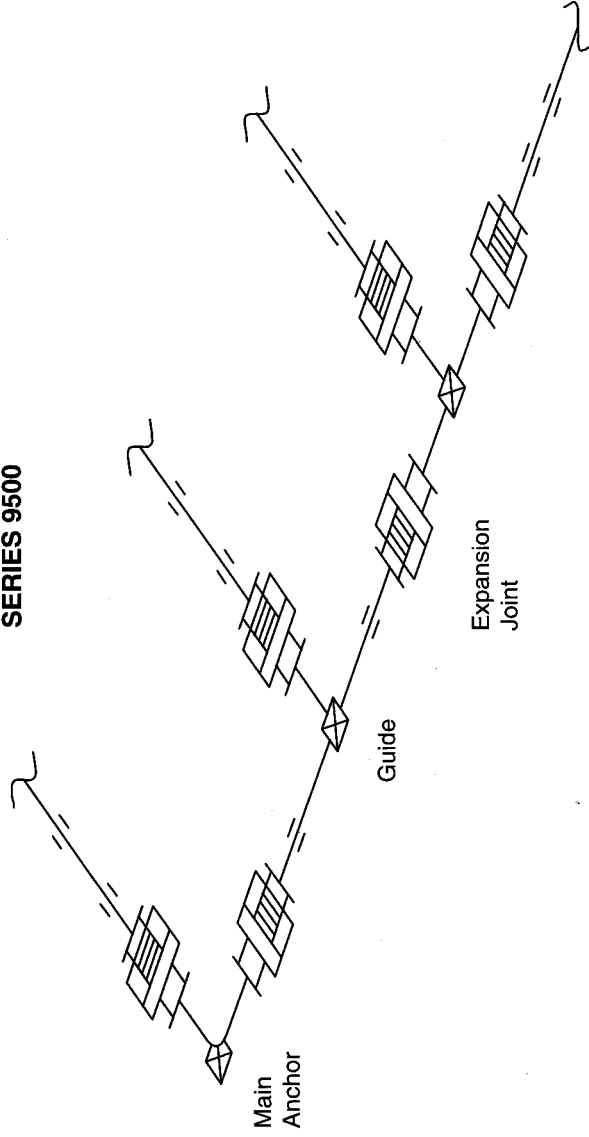

INTERMEDIATE ANCHOR PIPING SYSTEM

Series 1500 Inline Pressure Balanced Expansion Joint

-For short to medium axial movement-

Series 3500 Inline Pressure Balanced Expansion Joint

-For long axial movement-

Absorbs axial motion while eliminating pressure thrust loads on the piping system.



SERIES 1500



SERIES 3500

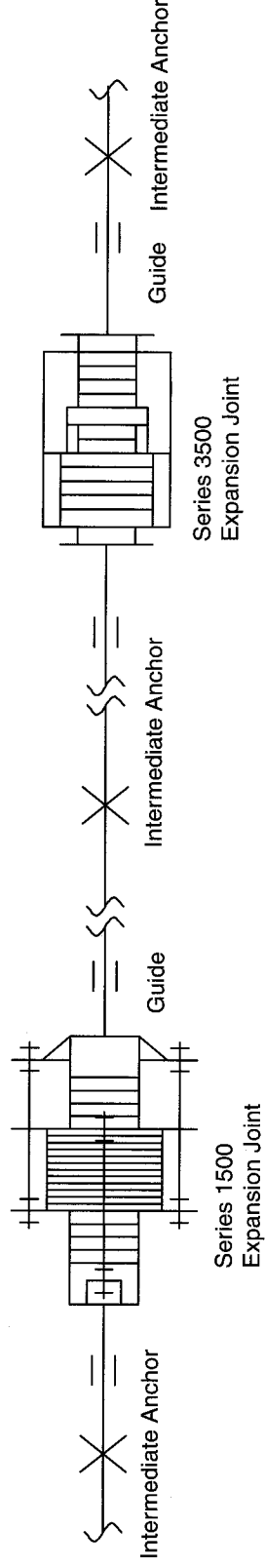

INTERMEDIATE ANCHOR PIPING

Series 1500 Inline Pressure Balanced Elbow

Absorbs axial motion while eliminating pressure thrust loads on the piping system.



SERIES 1500

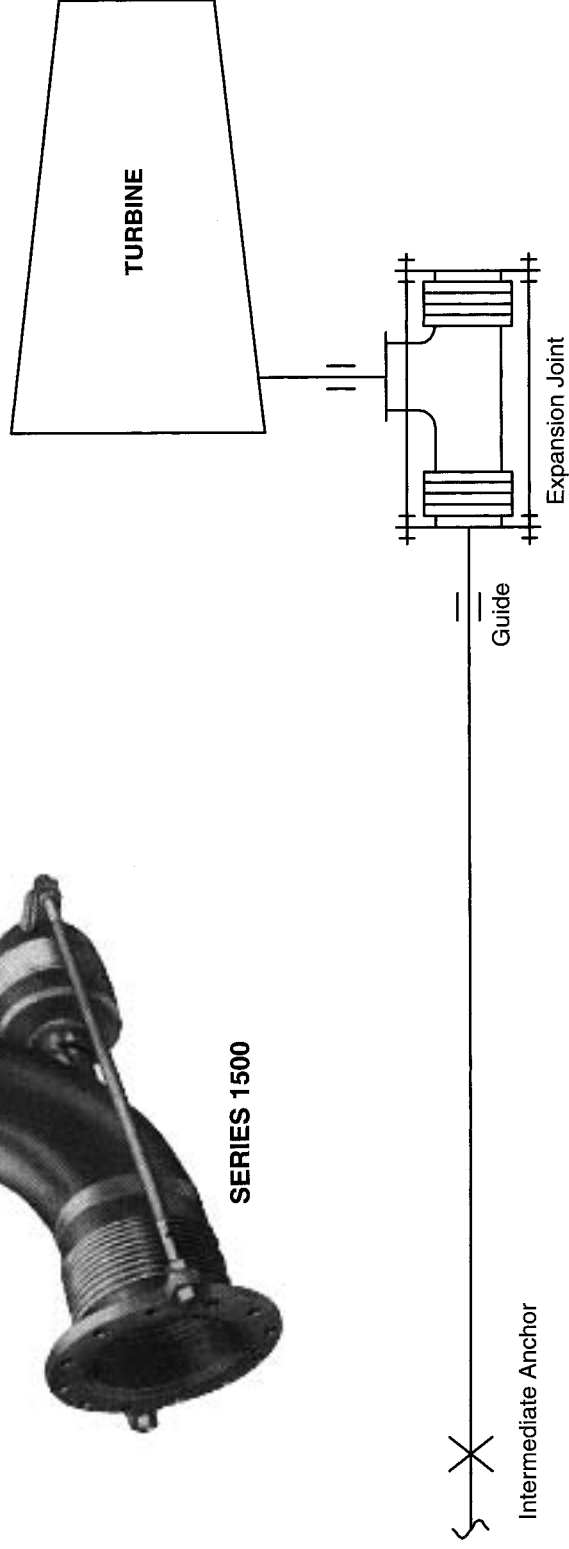

INTERMEDIATE ANCHOR PIPING SYSTEM

Series 1500 Universal Pressure Balanced Expansion Joint

Absorbs both axial and lateral movement but does not impose pressure thrust forces on critical equipment.



SERIES 1500

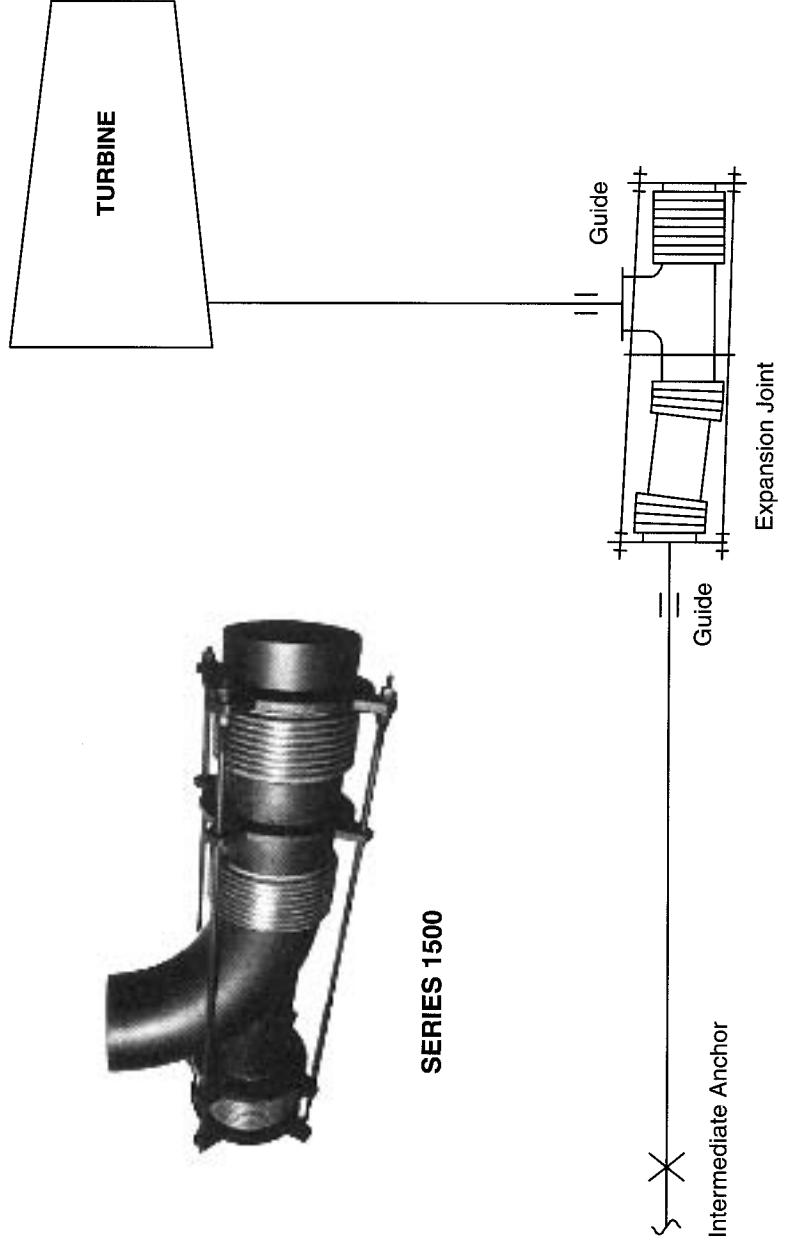

HANGER SUPPORTED PIPING SYSTEM

Series 1500 2-Hinge Expansion Joint "DOG LEG" System

Significantly reduces the bending stress.

Absorbs the equivalent movement of several rigid Dog Leg offsets.

No pressure thrust force.

No flex torque load.

Can be designed to support piping weight.



SERIES 1500

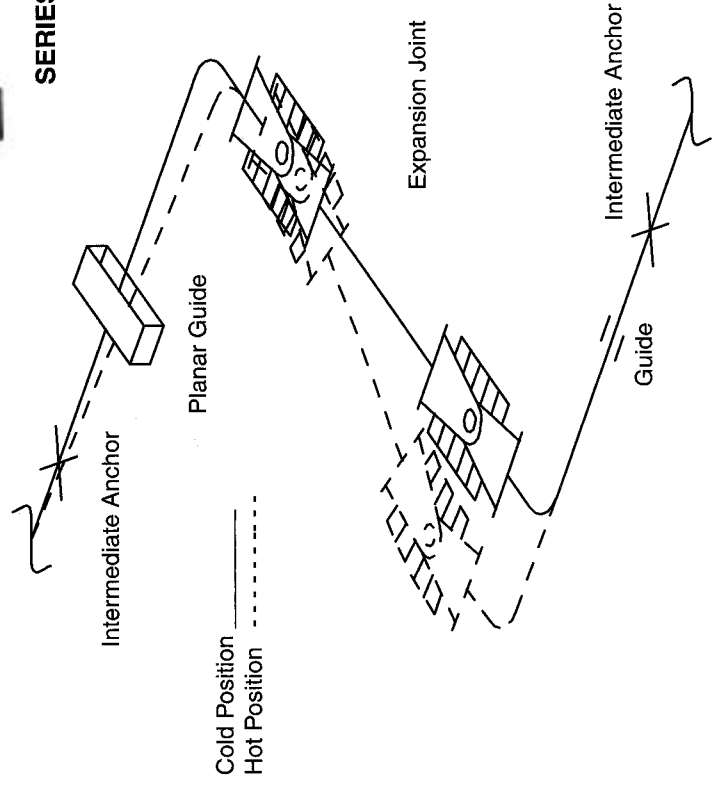

HANGER SUPPORTED PIPING SYSTEM

Series 1500 4-Hinge Expansion Joint "LOOP" System

Eliminates pipe bending stress.

Reduces the size of the loop.

Can absorb the equivalent movement of several rigid pipe loops.

No pressure thrust force.

No flex torque load.

Can be designed to support piping weight.



SERIES 1500

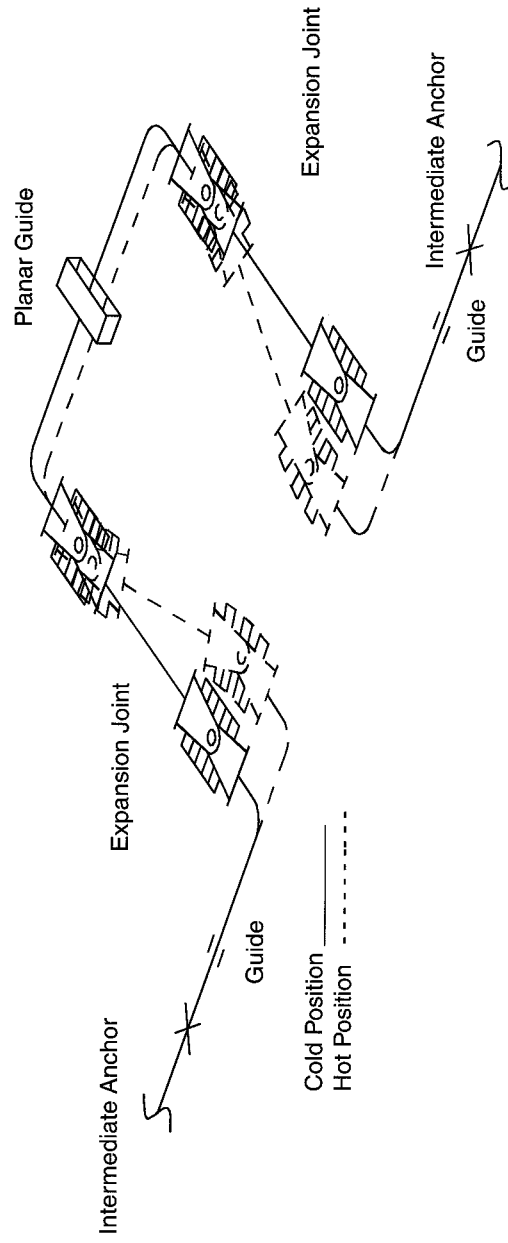

HANGER SUPPORTED PIPING SYSTEM

Series 1500 3-Hinge Expansion Joint "ELBOW" System

Absorbs axial movement in both legs of pipe.

Eliminates bending stress.

No pressure thrust force.

No flex torque load.

Can be designed to support piping weight.



SERIES 1500

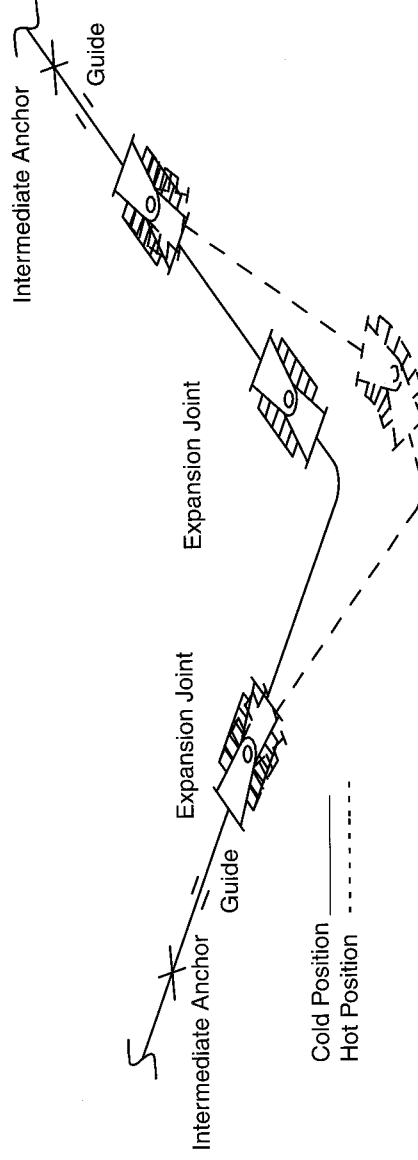

HANGER SUPPORTED PIPING SYSTEM

Series 1500 2-Hinge Expansion Joint System to Stationary Equipment
Absorbs lateral movement in branch lines as header line moves.
Eliminates bending stress.
No pressure thrust force.
No flex torque load.
Can be designed to support piping weight.



SERIES 1500

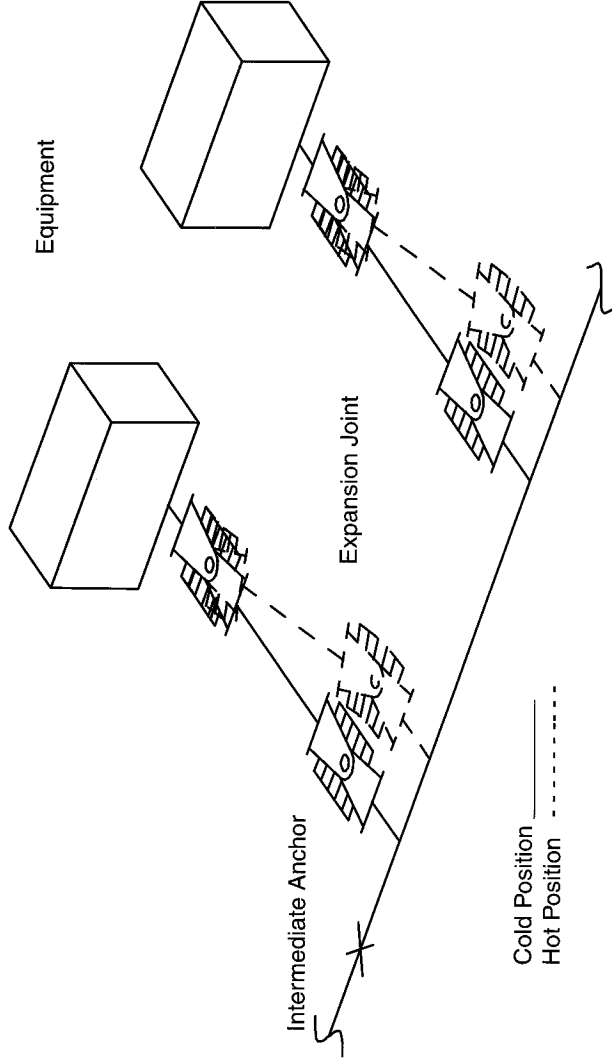

HANGER SUPPORTED PIPING SYSTEM

Series 1500 2-Gimbal, 1 Hinge Expansion Joint "DOG LEG"

Movement in 2 Planes

No bending stress.

Absorbs the equivalent movement of several rigid offsets.

No pressure thrust force.

No flex torque load.

Can be designed to support piping weight.



**SERIES 1500
HINGE**



**SERIES 1500
GIMBAL**

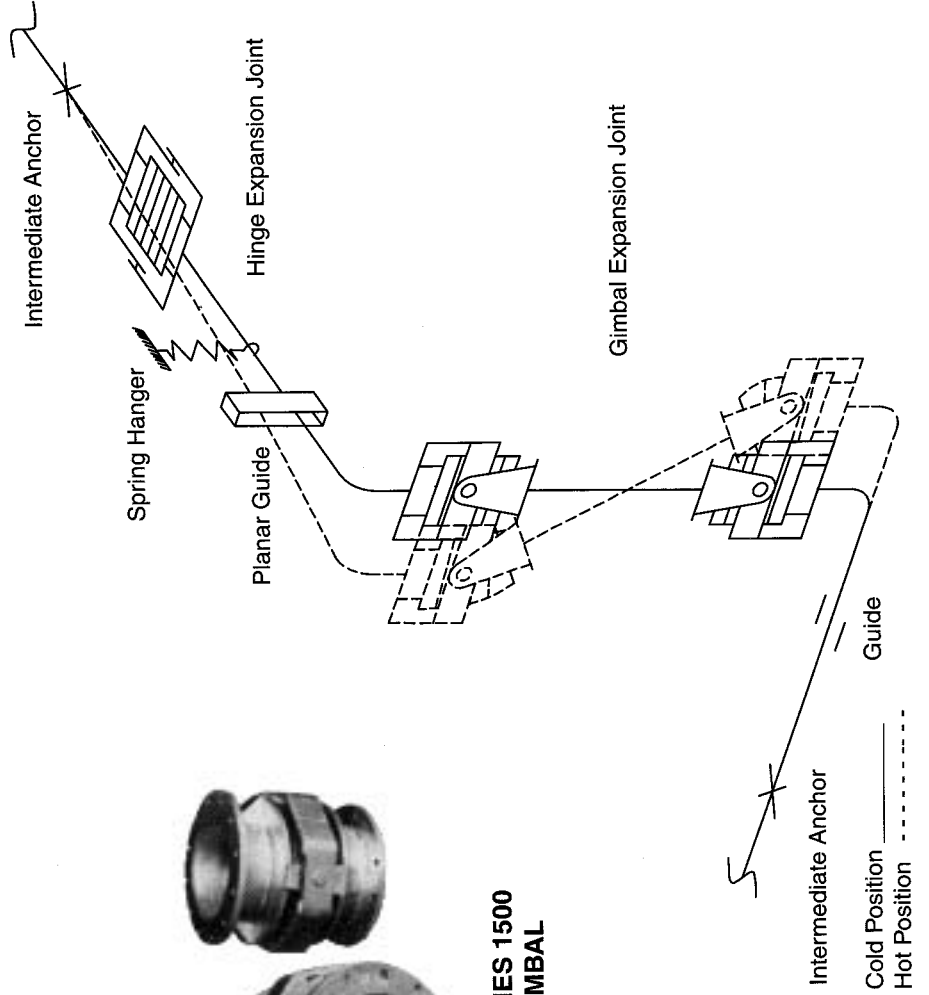

HANGER SUPPORTED PIPING SYSTEM

Series 1500 Universal Tied Expansion Joint "DOG LEG" System
Absorbs the equivalent movement of several rigid Dog Leg offsets.
Significantly reduces pipe bending stress.
No pressure thrust force.
No flex torque load.



SERIES 1500

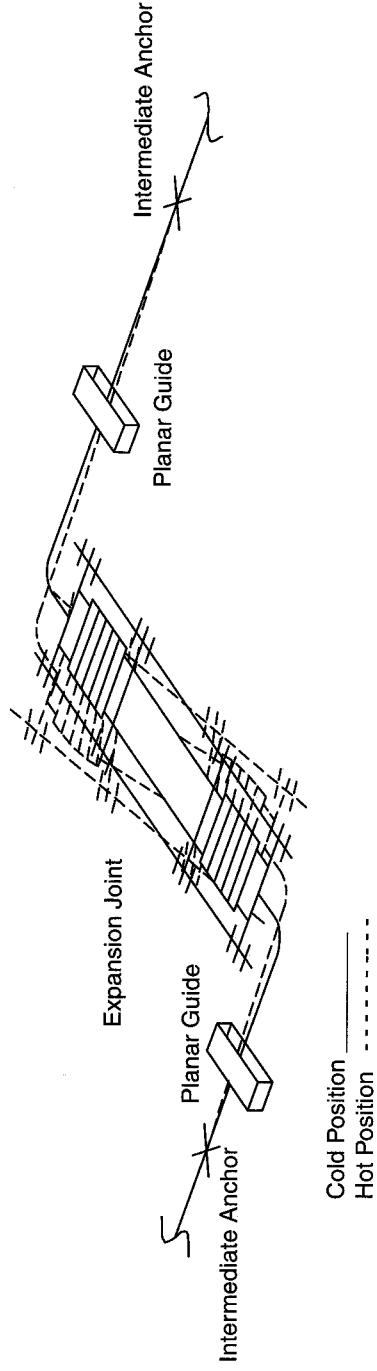

HANGER SUPPORTED PIPING SYSTEM

Series 1500 Universal Tied Expansion Joint for 2-Plane Movement

Absorbs axial movement of the pipe moving in 2 different planes.

Significantly reduces the bending stress.

No pressure thrust force.

No flex torque load.



SERIES 1500

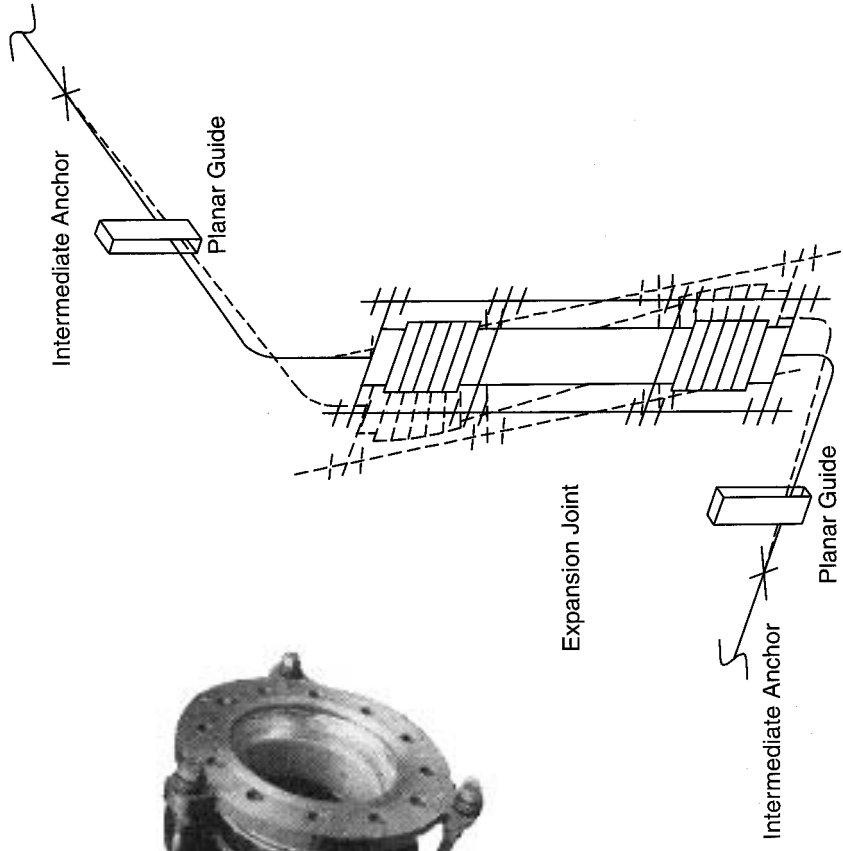

EQUIPMENT VIBRATION ISOLATION

Series 5500 Bellows Pump Connector
Extremely flexible assembly designed to protect critical mechanical equipment.
Prevents shock and vibration.
Reduces noise due to fluid pulsation and vibration.



SERIES 5500

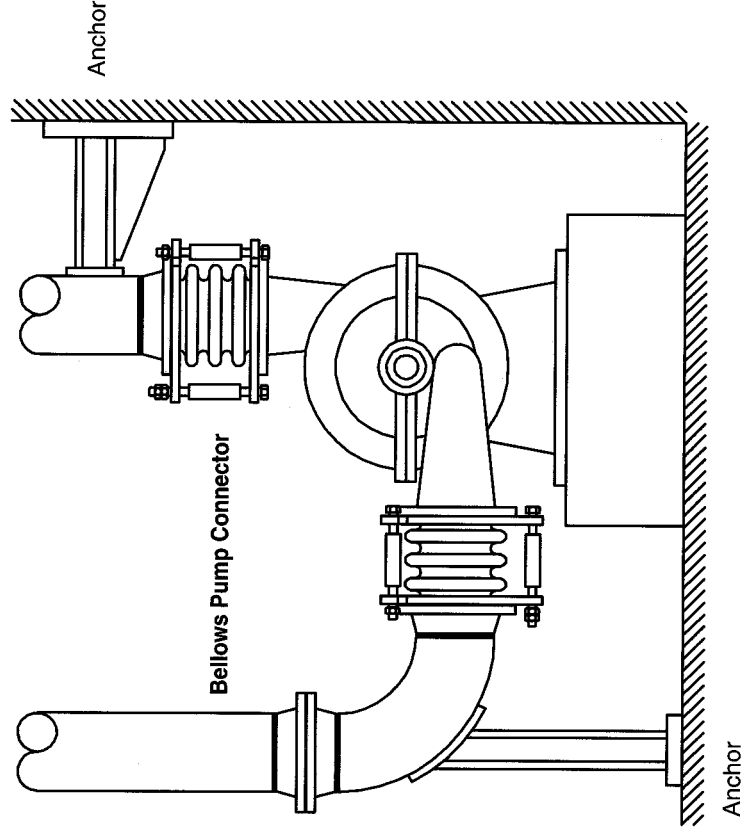

EQUIPMENT VIBRATION ISOLATION
Series 4500 Flexible Metal Connector
Prevents shock and vibration.
Reduces noise in piping systems.



SERIES 4500

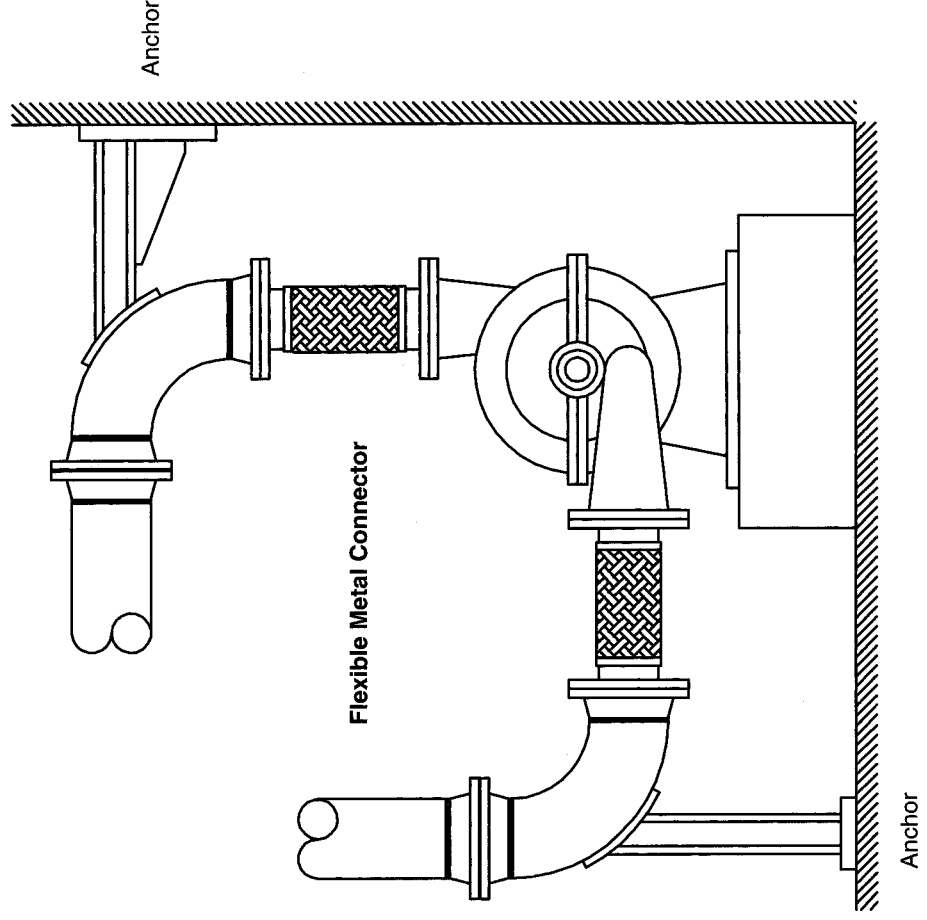

INFORMATION NEEDED FOR A QUOTATION

1. Always provide as much information as you can.
2. It is very helpful to understand the customer's intent (application).
3. Whenever possible, please try to get the following as a minimum:

Size- Diameter if round; width and height if rectangular; overall length if dimension is critical.

Temperature-Maximum

Pressure-Design and maximum

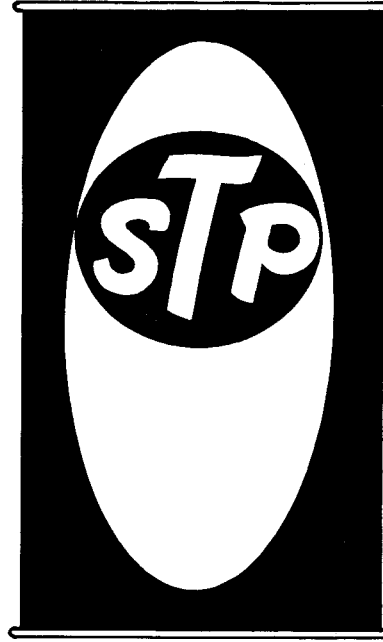

Media-Description

Motion-Axial, lateral, angular

Materials-Any special materials

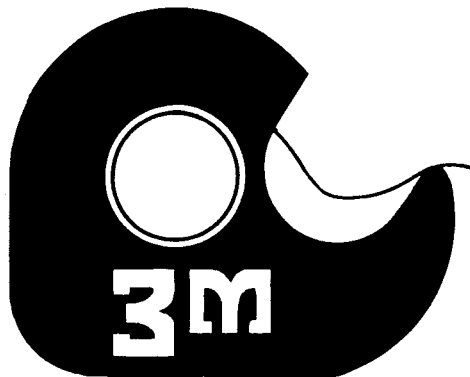



Packed Expansion Joints

PACKED EXPANSION JOINT



- Suitable for virtually any axial movement.
- Unaffected by water hammer.
- Sealant packing may be injected while expansion joint is in service.
- Internal guides and stops insure alignment and prevent over compression or over extension of the traveling pipe.
- External guiding is necessary but minimized by integral guides in the joint.

PACKED EXPANSION JOINT

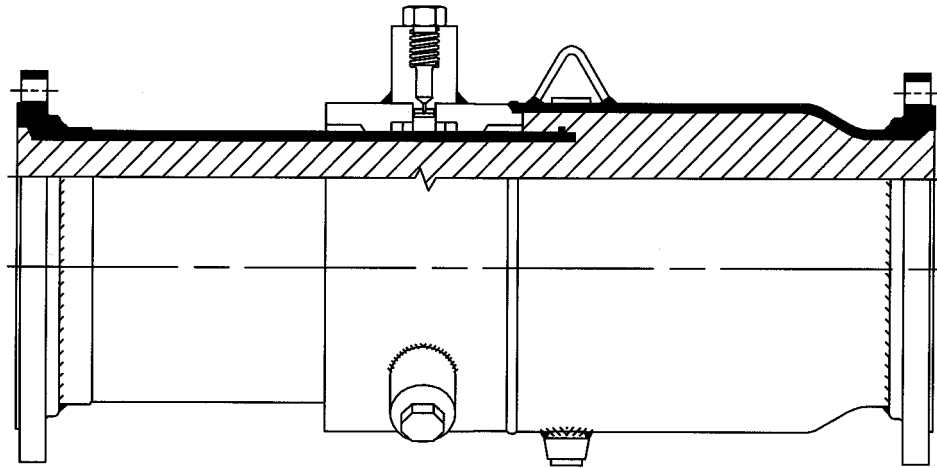

HOUSING

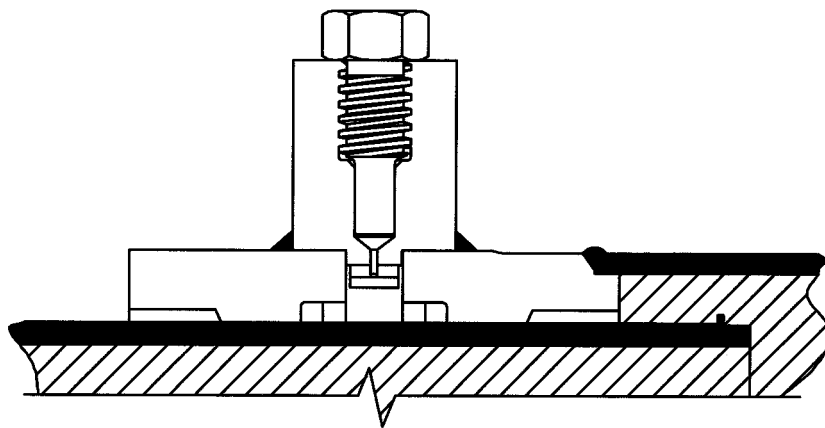

PACKED EXPANSION JOINT APPLICATION

Expansion of a piping run due to an elevated operating temperature (axial motion).

Assumptions:

1. The piping system is properly supported and guided.
2. The weight of the piping system and the fluid being conveyed is carried by properly designed supports and hangers and is, therefore, not included.
3. Friction forces caused by guides, supports, and other hardware extraneous to the piping are zero.

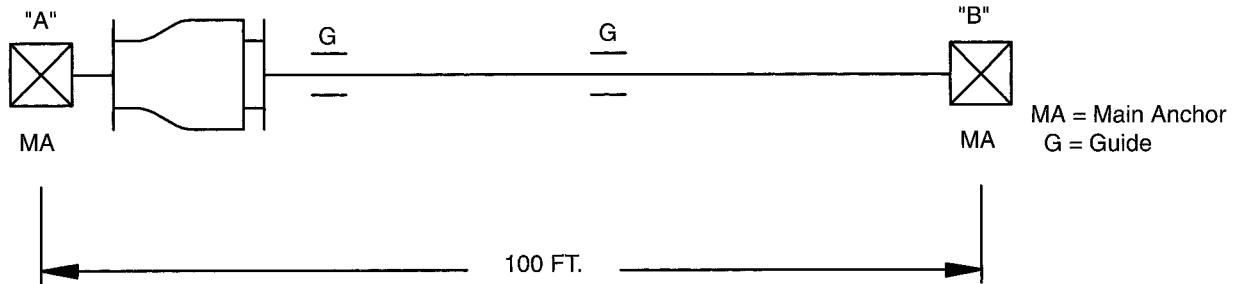

Problem: A straight run of 8" diameter carbon steel pipe is 325 feet long, and anchored at each end, is to operate at 125 psig saturated steam (350°F). The installation temperature is 70°F. A single packed expansion joint is utilized to absorb the thermal growth of the pipe. Thermal growth is determined to be 7.35 inches.*

What are the forces acting on the anchors and guides?

- A. Operating conditions
- B. Cold water hydrostatic test at 1.5 x design

Supply: SERIES 6500 PACKED EXPANSION JOINT 6501-167-8
 Friction Force: 10000 Lb.* *
 Effective area: 55.9 in.² * * *

Solution A - Operating Conditions:

Forces acting on main anchor "A"

$$F_x = -F_s - F$$

$$F_x = -6989 - 10000$$

$$F_x = -16989 \text{ Lbs.}$$

Where:

F_s = The static thrust due to internal pressure-Lbs.
 = (Effective Area) (Design Line Pressure)
 = (55.9 in.²) (125 Lb./in.²)
 = 6989 Lbs.

F = The force required to deflect the expansion joint
 = (Friction Force)
 = 10000 Lbs.

Forces acting on main anchor "B"

$$F_x = F_s + F$$

$$F_x = 6989 + 10000 = 16989 \text{ Lbs.}$$

Maximum lateral forces acting on the alignment guides are:

$$\text{Force acting on main anchor} \times 0.15$$

$$\text{Maximum lateral force} = 16989 \times 0.15$$

$$\text{Maximum lateral force} = 2548 \text{ Lbs.}$$

* 6500 Series Catalog: "Thermal Expansion of Pipe" per 100 feet, carbon and wrought iron
 ** SERIES 6500 CATG 986 PAGE 3
 *** SERIES 6500 CATG 986 PAGE 3

PACKED EXPANSION JOINT APPLICATION (CONTINUED)

Solution B - Hydrostatic Test Conditions

Forces acting on main anchor "A"

$$F_x = -F_s - F$$

$$F_x = -10482 - 0$$

$$F_x = -10482 \text{ Lbs.}$$

Where:

F_s = The static thrust due to internal pressure-Lbs.

$$= (\text{Effective Area}) (\text{Design Line Pressure})$$

$$= (55.9 \text{ In.}^2) (187.5 \text{ Lb./In.}^2)$$

$$= 10482 \text{ Lbs.}$$

F = (Friction Force)

$$= 0 \text{ Lbs. (1)*}$$

Forces acting on main anchor "B"

$$F_x = F_s + F$$

$$F_x = 10482 + 0$$

$$F_x = 10482 \text{ Lbs.}$$

Maximum lateral forces acting on the alignment guides are:

Force acting on main anchor x 0.15

$$\text{Maximum lateral force} = 10482 \times 0.15$$

$$\text{Maximum lateral force} = 1572 \text{ Lbs.}$$

*(1) Since the Hydrostatic Test was conducted at ambient temperature (the same temperature at which the system was installed), the expansion joint has not been deflected and no force exerted.

The maximum forces are exerted during operating conditions. The main anchor must be designed to absorb the pressure thrust force and the friction force.

Since the maximum lateral forces that can act on the alignment guides are a function of the forces acting on the main anchors, they are also at a maximum during operating conditions.

Recommended Use of Pipe Alignment Guides:

$$\text{1st Guide: } 10 \times D = 10 \times 8 = 80" = 6'8"$$

$$\text{Additional Guides} = 47" \text{ max spacing}$$

In using expansion joints to solve thermal expansion problems you must:

- Specify the correct expansion joint design
- Provide main anchors that will absorb the maximum pressure thrust.
- Guide the piping properly.

MAIN ANCHOR PIPING SYSTEM
Series 6500 Packed Expansion Joint
Series 9500 Pipe Alignment Guide
for movement up to 12".



SERIES 9500



SERIES 6500

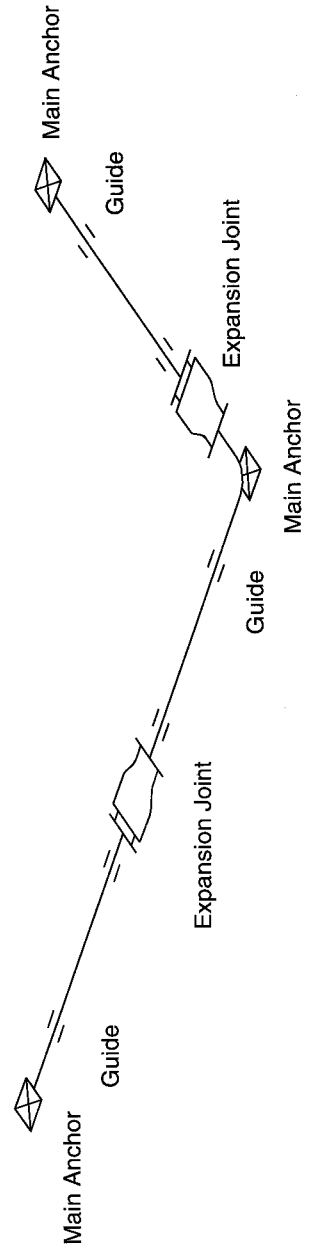

MAIN ANCHOR PIPING SYSTEM

Series 6500 Dual Packed Expansion Joint

Series 9500 Pipe Alignment Guide

By using a dual unit with an intermediate anchor at the center of a long run of pipe, movement up to 24" can be handled by the expansion joint.

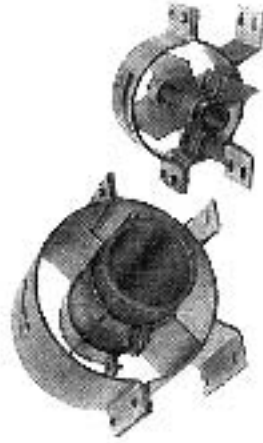
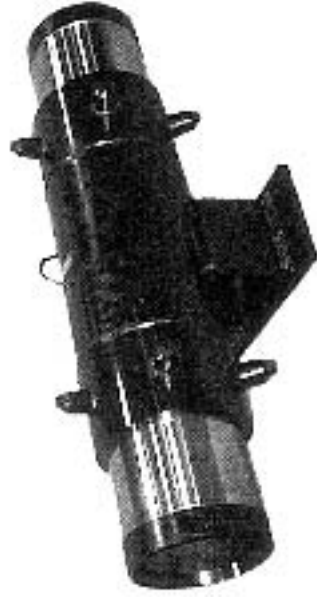

SERIES 9500

SERIES 6500

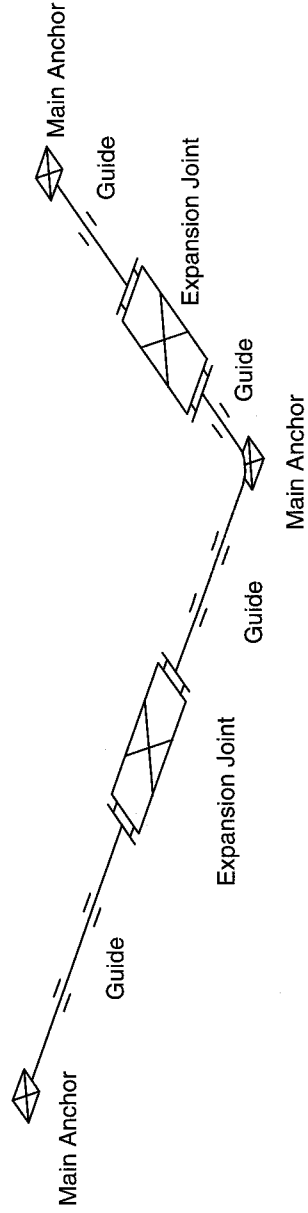



In-line Pressure Balanced Universal Expansion Joint



“IN-LINE PRESSURE BALANCED UNIVERSAL EXPANSION JOINT

Axial thermal growth can occur in piping systems that have no provision for the heavy main anchors necessary to react expansion joint pressure thrust forces. A common case might be a direct line between vessels or rotating equipment.

The In-Line Pressure Balanced Expansion Joint is a specialized expansion joint that accepts axial motion without the attendant pressure thrust forces common to other styles of axial expansion joints. This is achieved by cross connecting two working or line bellows to a center mounted balancing bellows. The balancing bellows is sized at exactly twice the total effective area as the line bellows so that internal pressure will produce a force that is equal to the force of the two line bellows. The mechanical crosslinking devices contain these equal but opposing forces internally within the expansion joint. Externally transmitted forces are therefore reduced to only the spring force of the bellows as they deflect to accommodate the thermal expansion.

Hyspan recognized that many such applications produce lateral offset and angular rotation in addition to the primary axial motion. Since the conventional crosslinking method accepts very slight lateral offset and no angular rotation capability, two unique patented designs were developed by Hyspan which result in In-Line Pressure Balanced Expansion Joints with full range-of-motion capability. For the first time, the designer has products available that can accommodate axial and out-of-plane motions without the penalty of pressure thrust.

- **Eliminates pressure thrust**
- **Eliminates main anchors**
- **Significantly reduces loads and forces on critical equipment**
- **Does not require a change in direction of the piping system**
- **Absorbs axial lateral and angular motion**

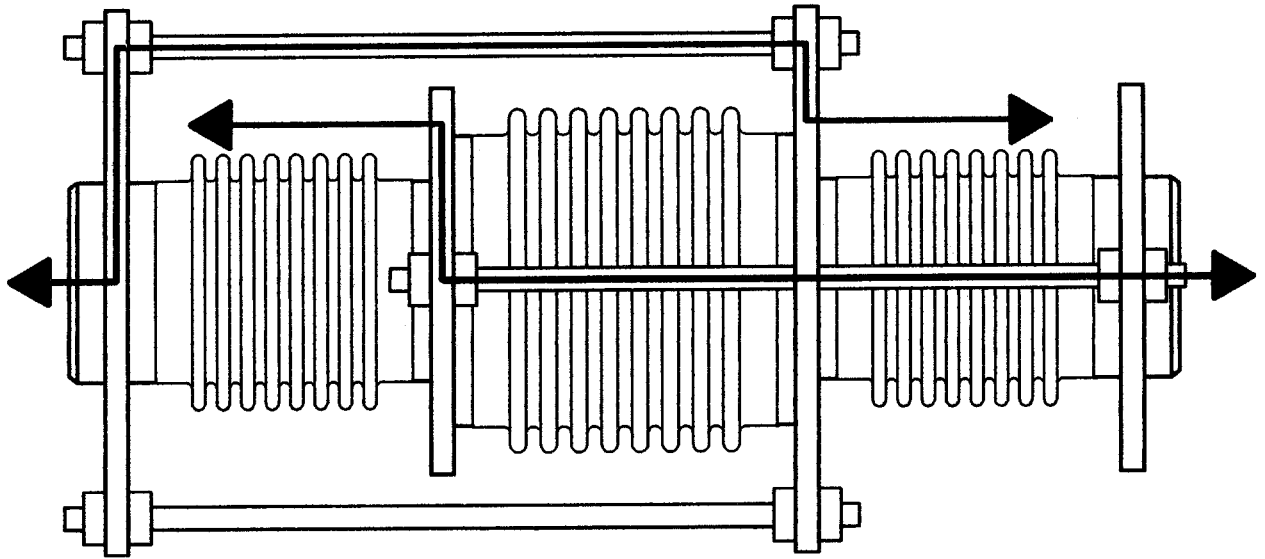

**CONVENTIONAL IN-LINE
PRESSURE BALANCED**

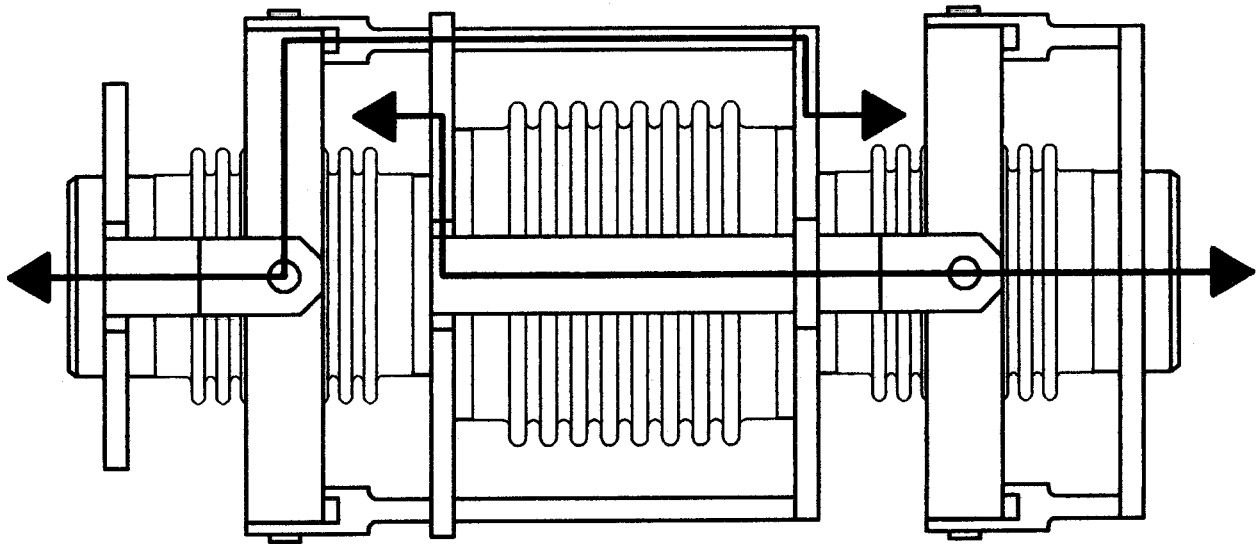

**HYSPAN PATENTED IN-LINE
PRESSURE BALANCED UNIVERSAL**

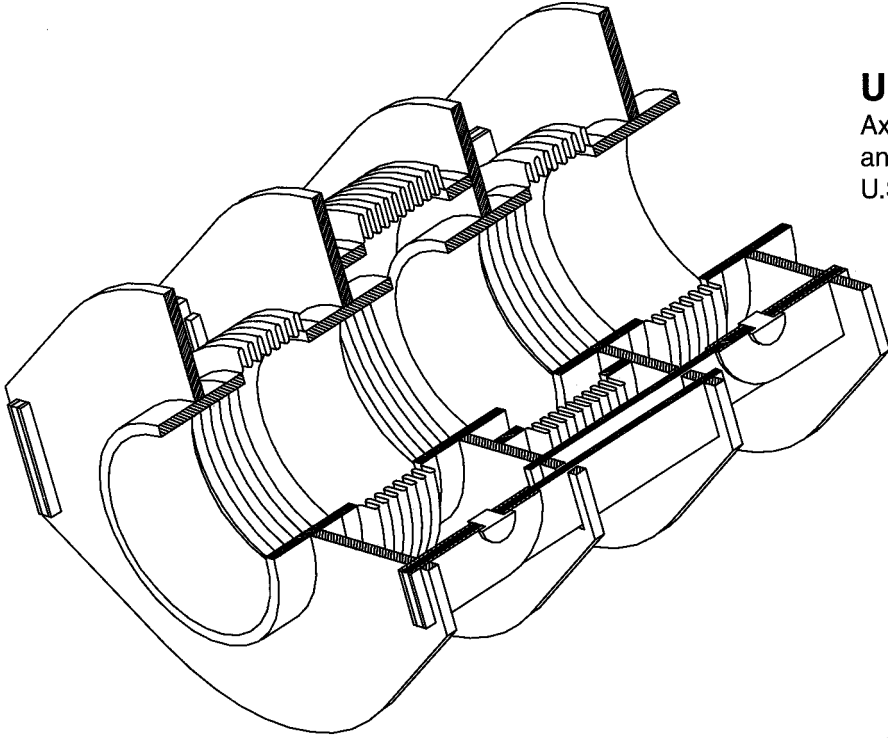

UNIVERSAL HINGE

Axial with single plane lateral
and angular movement.

U.S. Patent No. 5248170

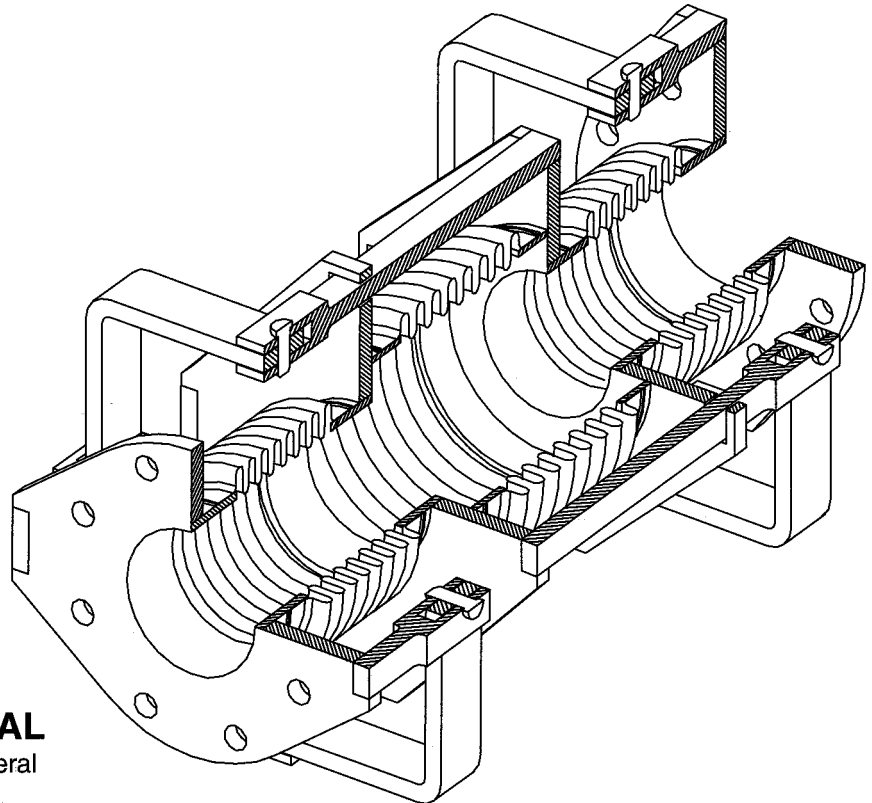

UNIVERSAL GIMBAL

Axial with multiple plane lateral
and angular movement.66

U.S. Patent No. 5299840



Hyspan

Hyspan Precision Products, Inc. 1685 Brandywine Ave. Chula Vista, CA 91911

TELEPHONE (619) 421-1355

FAX (619) 421-1702

Printed in U.S.A.